

The background of the cover features a close-up, high-angle view of several OHMA weld cylinders. The cylinders are arranged in a circular pattern, with some showing their ports and others showing their end caps. The lighting is dramatic, highlighting the metallic surfaces and the precision engineering of the components. A subtle grid pattern is overlaid on the image, adding a technical feel.

OHMA[®] WELD CYLINDER PRODUCT GUIDE

Version 3.0

The logo for Centerline (Windsor) Limited. It features the word "centerline" in a stylized, blue, sans-serif font. The letter "c" is unique, with a vertical line extending upwards and a horizontal line extending to the left, forming a crosshair shape. Below the word "centerline" is the text "(WINDSOR) LIMITED" in a smaller, blue, sans-serif font. The entire logo is centered on a dark background with a subtle grid pattern.

centerline
(WINDSOR) LIMITED

centerline

OHMA[®] CYLINDER

Features & Benefits

Innovative product design and attention to manufacturing detail are reflected in the OHMA[®] cylinder system. The following attributes and advantages best illustrate the OHMA[®] cylinder's adaptability to a wide range of applications.



- **Ability to function in any position**

A convenient, remote fluid reservoir supplies fluid to the OHMA[®] cylinder to allow it to operate in any orientation. Any air that enters the system will naturally be bled after one or two cycles. With the OHMA[®] cylinder, the application dictates its position... not the cylinder.

- **Compact & Efficient**

The compact size of the OHMA[®] cylinder results in substantial savings in air consumption. Compact machine designs can be developed to take advantage of the OHMA[®] cylinder's small physical size thus realizing additional savings (i.e., reduced frame size, shorter supply lines, etc.)

- **Extensive Force Range**

The OHMA[®] cylinder can be adjusted to produce a broad range of weld force outputs to overcome poor part fit and accommodate variable weld conditions.

- **Design Options**

Custom OHMA[®] cylinders can be manufactured to suit specific applications. Custom ratios, power strokes, total strokes and rod end styles can normally be accommodated to maximize process efficiencies.

- **Low-Impact**

The OHMA[®] cylinder's low-impact advance stroke results in prolonged electrode life, reduced part deformation and decreased overall shock to the equipment. With the OHMA[®] weld cylinder, electrode skidding can be controlled or even eliminated due to its low impact force.

- **Simple Construction & Operation**

With only two moving parts, the OHMA[®] cylinder is easy to operate and maintain. The simple design of the cylinder is easily serviceable and does not require special skills, tools, or equipment.

- **Dependability**

The OHMA[®] cylinder is a proven product. Its rugged, dependable construction is intended for long term, demanding applications. With a program of routine preventive maintenance, the OHMA[®] cylinder will provide reliable, trouble-free operation for years to come.



Contents

Terminology	2
Components & Model Number	3
System Requirements & Sequence of Operation	4
Cylinders	
RH Mount	5-7
RC Mount	8-10
STUD Mount	11-13
FBL Mount	14-16
FF Mount	17-19
FNP Mount	20-22
PIN Mount	23-24
FD Mount	25-26
Cylinder Hook-up & Operating Instructions	27
Reservoir Hook-up & Operating Instructions, Valve Selection	28
Standard Fluid Reservoirs	29
ISO & ASB Fluid Reservoirs	30-31
Pneumatic Schematic-Standard Hook-up	33
Pneumatic Schematic-Delicate Touch/Blocking Valve Hook-up	34
ISO & ASB Fluid Reservoir Hook-up	35
Other Products	36-37

Terminology

Ratio

The ratio represents the multiplication factor by which the cylinder generates its work force. By making an adjustment in the intensification pressure, the cylinder may be operated at a wide range of force outputs. For example, a 32:1 ratio OHMA® cylinder will produce 1600 lbs of work force at 50 PSI (50 x 32); at 80 PSI, the same cylinder will produce 2560 lbs. of force (80 x 32). Each cylinder chart identifies the ratio and presents a force range graph which applies to each particular cylinder model.

Using 100 PSI of compressed air for operations you receive the following outputs:

Bore Size (in.)	Conventional Cylinder	Standard OHMA® Cylinder Ratio Options					
		Ratio	Max. Force Output	Ratio	Max. Force Output	Ratio	Max. Force Output
1-3/4	240 lbs	13:1	1300 lbs	19:1	1900 lbs		
2	314 lbs	22:1	2200 lbs	32:1	3200 lbs	40:1	4000 lbs
2-5/8	541 lbs	37:1	3700 lbs	49:1	4900 lbs	66:1	6600 lbs

Power Stroke

The power stroke represents the stroke the cylinder will have in the working portion of the sequence of operation. The OHMA® cylinder initially strokes to the work at a low force. Once contact is made, the intensification stage is sequenced to produce the actual work force. The power stroke is limited to and is a function of the cylinder's internal configuration. For example, a 32:1 ratio cylinder, 3" overall stroke, .20 power stroke operating at 60 PSI will initially make contact with the work as if it were an air cylinder. Since this cylinder is a 2" bore with an effective piston area of 3.1416", the advance force will be 188 lbs (60 PSI x 3.1416). Once sequenced into high pressure, the cylinder will travel for a maximum distance of 0.20" at 1920 lbs (60 PSI x 32 ratio). Although the power stroke may appear to be short, a vast majority of welding applications will only require a work stroke of this length.

Total Stroke

The total stroke is the sum of the available advance stroke and the power stroke. Advancing the cylinder the length of its total stroke before intensification will result in the cylinder bottoming out. This could lead to a cylinder breakdown. Aside from this stipulation, the OHMA® cylinder will function consistently at any advance stroke position.

Bleeder Port

Most OHMA® cylinders are equipped with an air bleeder port. Weld cylinder styles normally have a bleeder screw located in the working piston rod. The bleeder port has been included to facilitate the purging of air, if required, from the fluid portion of the system. Normally, the OHMA® cylinder is self-bleeding since the fluid reservoir is mounted above the cylinder fluid port and naturally travels out of the cylinder to be exhausted via the fluid reservoir.

In the unlikely event that the fluid reservoir begins to lose significant amount of fluid, through normal atomization and evaporation, the fluid level may eventually drop below the recommended level where the fluid may start to aerate. In such situations, the fluid reservoir will require an addition of fluid to return to its proper operating level and the bleeder may need to be used to release any air which may be trapped in the system.

Seals

The OHMA® cylinders make use of standard BUNA N and polyurethane 70 Durometer O-rings and one high pressure "Uni-Seal". The Uni-Seal is a loaded U-cup seal which withstands the high pressure developed in the cylinder.

Components & Model Number

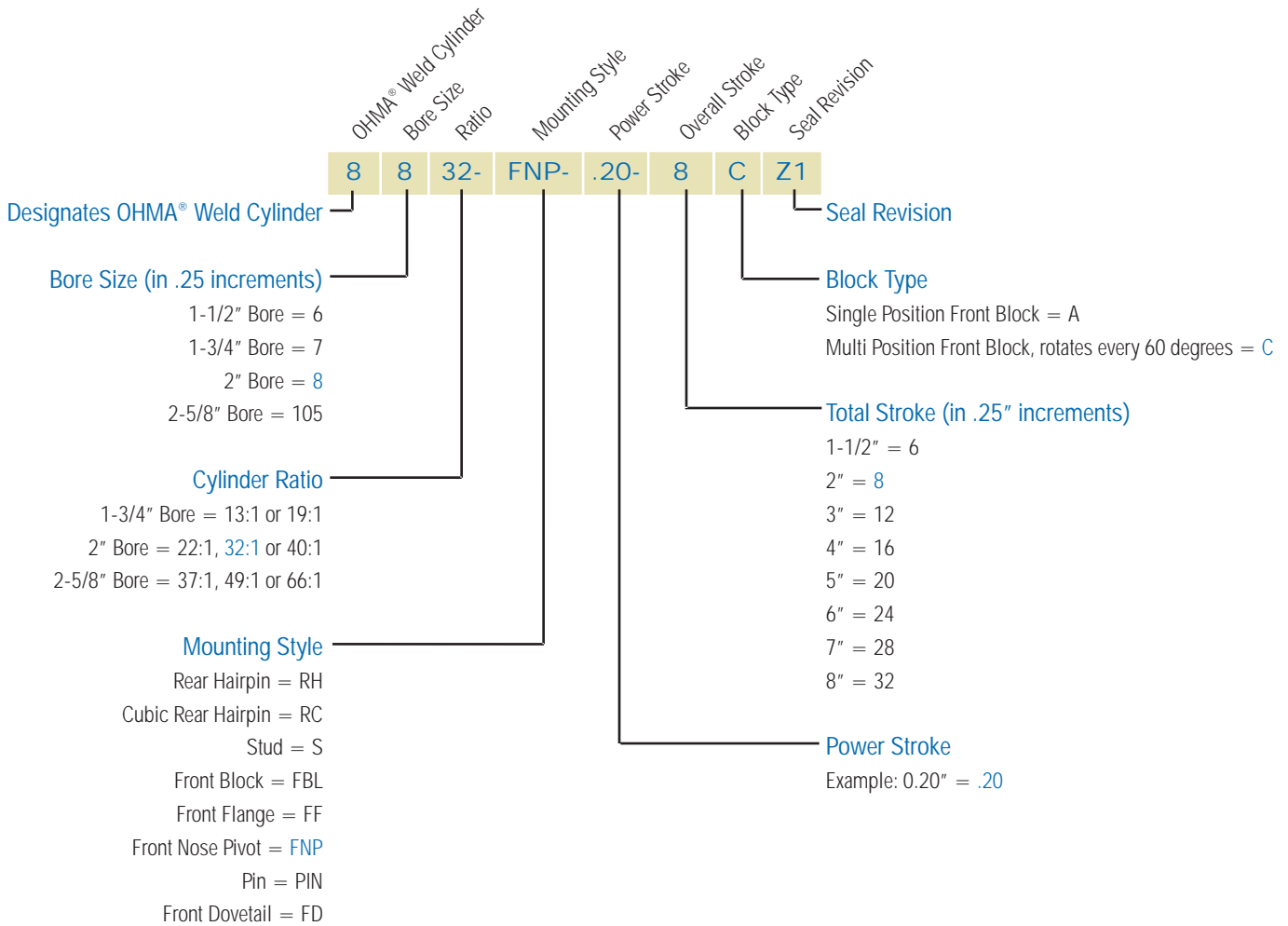
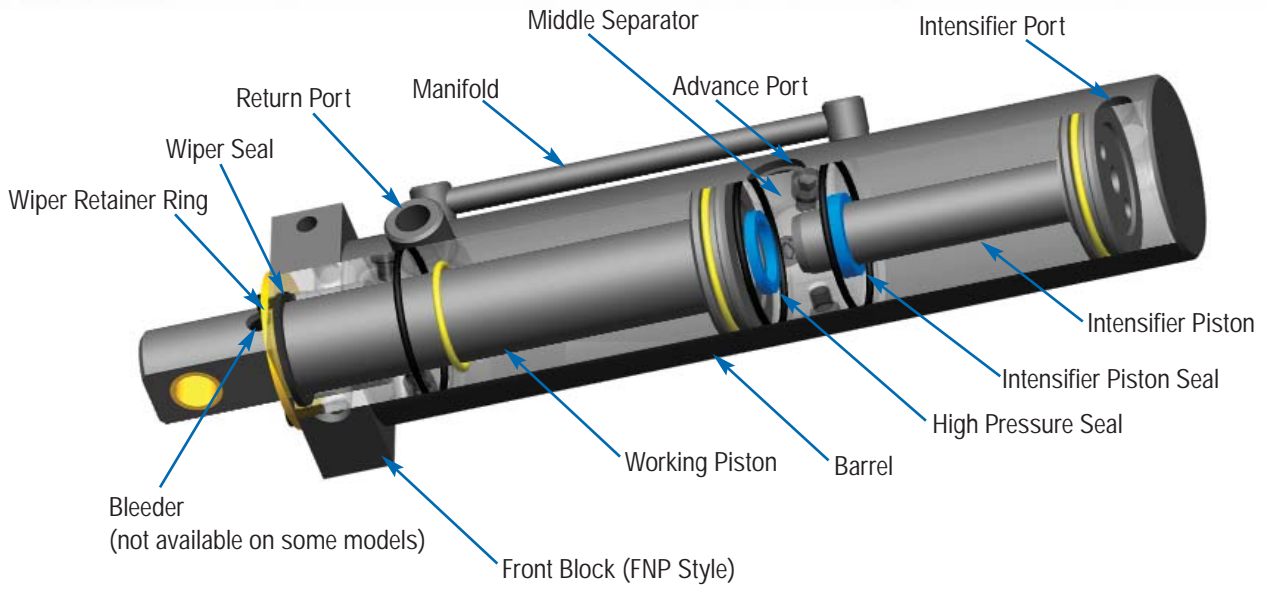

System Requirements & Sequence of Operation

System Requirements

The following items must be provided in order to properly operate an OHMA® cylinder:

- 1 CenterLine Fluid Reservoir or a compatible substitute
- 2 Four-way Valves or 1 Three-way Valve & 1 Four-way Valve
- 1 Air Supply Filter
- 1 Air Regulator (2 Regulators for Delicate Touch)

A method of independently sequencing the two valves to produce the desired sequence of operation. This can normally be achieved with the use of two timers. Contact CenterLine for additional control information.

OHMA® Cylinder Sequence of Operation

1. CYLINDER AT REST POSITION

In this view, line pressure (air) is directed to Port EE1 (Return Port) to maintain the working and intensifier pistons in a retracted position. Port EE3 (Intensifier Port) and the fluid reservoir are vented to atmosphere. Ports EE1 and EE2 are operated with an advance return valve and EE3 is operated with an intensification valve.

2. LOW PRESSURE ADVANCE

During the first stage of the cylinder's operation, air pressure is directed to the top of the fluid reservoir to move fluid into the OHMA® cylinder via Port EE2 (Advance Port). The low pressure fluid causes the working piston to stroke forward and meet the work at low impact. Ports EE1 and EE3 are vented to atmosphere.

3. POWER STROKE

Regulated air pressure is applied to Port EE3 to drive the intensifier piston forward. This piston advances through the middle separator to block all incoming fluid at Port EE2 and seal the OHMA® cylinder fluid chamber. As the intensifier piston strokes into the fluid, trapped fluid is displaced to produce the power stroke.

4. RETURN STROKE

Once the work is completed, air pressure is again directed to Port EE1 while EE2 and EE3 go to atmosphere pressure simultaneously. This causes the pistons to return to their rest position.

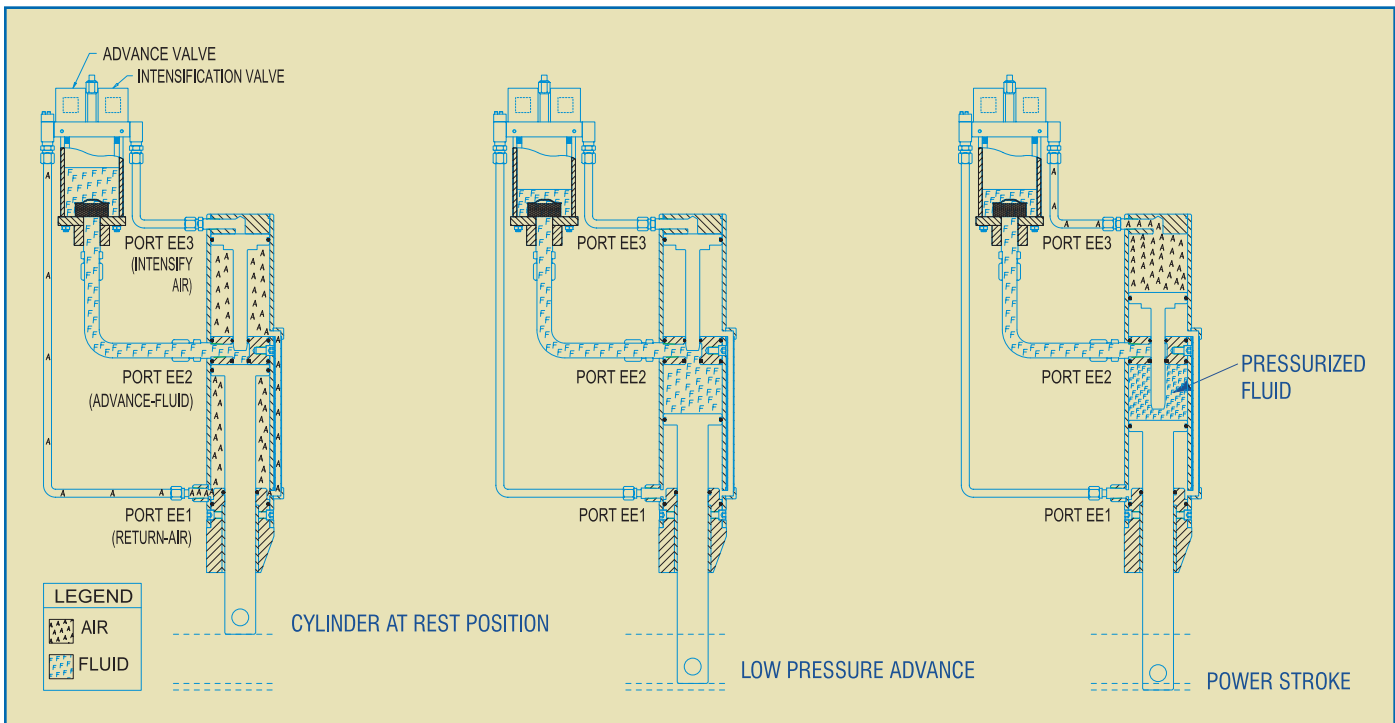

1-3/4" BORE RH Mount

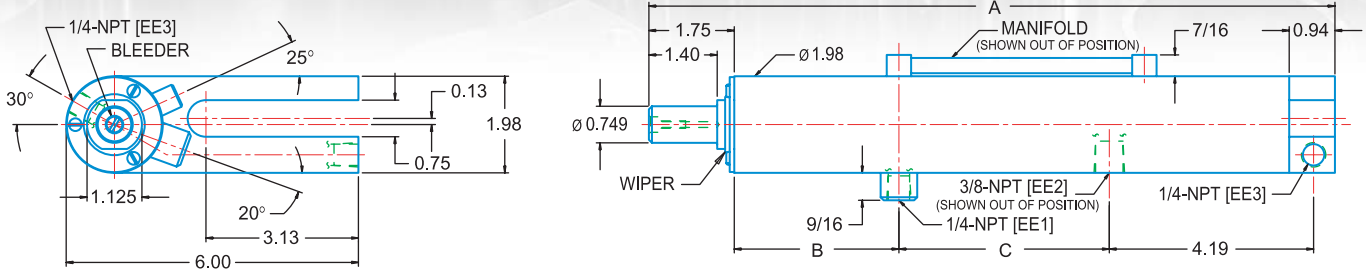

EE1 - RETURN PORT [AIR] EE2 - ADVANCE PORT [FLUID] EE3 - INTENSIFIER PORT [AIR]
RETURN FORCE (AT 100 PSI): 140 LBS.

Model No.	Total Stroke (in.)	Power Stroke (in.)	A (in.)	B (in.)	C (in.)	Fluid Req'd (cu. in.)
Ratio 13:1						
8713-RH-.29-6AZ1	1-1/2	0.29	11-1/16	1-7/8	2-13/16	4
8713-RH-.29-8AZ1	2	0.29	12-1/16	2-3/8	3-5/16	5
8713-RH-.29-12AZ1	3	0.29	14-1/16	3-3/8	4-5/16	7
8713-RH-.29-16AZ1	4	0.29	16-1/16	4-3/8	5-5/16	10
8713-RH-.29-20AZ1	5	0.29	18-1/16	5-3/8	6-5/16	12
8713-RH-.29-24AZ1	6	0.29	20-1/16	6-3/8	7-5/16	14
Ratio 19:1						
8719-RH-.25-6AZ1	1-1/2	0.25	11-1/16	1-7/8	2-13/16	4
8719-RH-.25-8AZ1	2	0.25	12-1/16	2-3/8	3-5/16	5
8719-RH-.25-12AZ1	3	0.25	14-1/16	3-3/8	4-5/16	7
8719-RH-.25-16AZ1	4	0.25	16-1/16	4-3/8	5-5/16	10
8719-RH-.25-20AZ1	5	0.25	18-1/16	5-3/8	6-5/16	12
8719-RH-.25-24AZ1	6	0.25	20-1/16	6-3/8	7-5/16	14

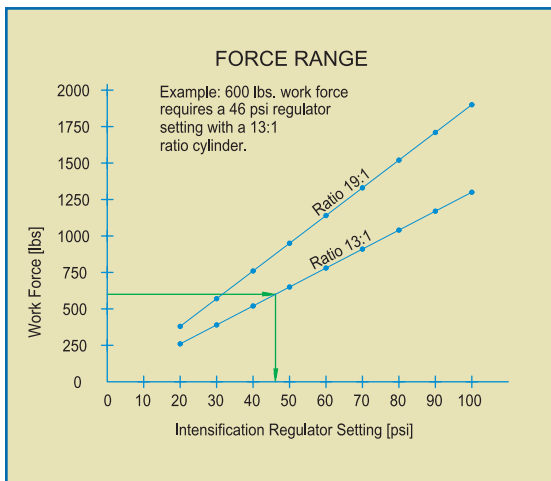

OHMA® Weld Cylinder
Bore: 1-3/4"
Ratio: 13:1
Mounting Style: Rear Hairpin
Power Stroke: 0.29"
Total Stroke: 3"
Front Block: Single Position
Seal Revision: Z1

8 7 13- RH- .29- 12 A Z1
CODING EXAMPLE

Rod end style, port location, total stroke, ratio and power stroke modifications are available upon request. For details, consult with CenterLine.

2" BORE RH Mount

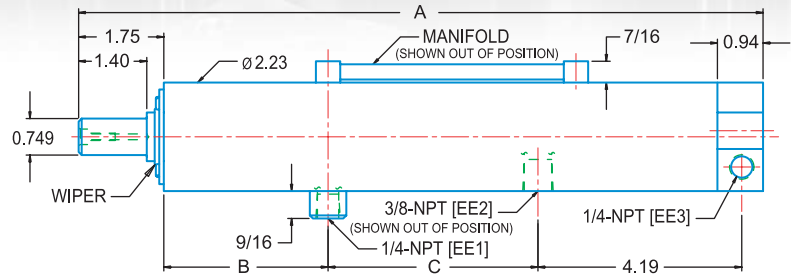
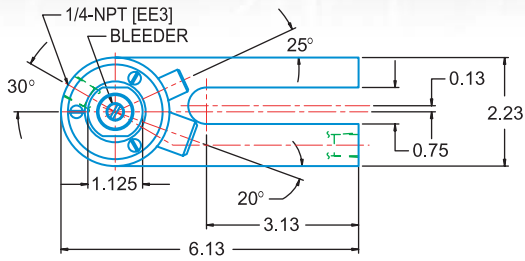

EE1 - RETURN PORT [AIR] EE2 - ADVANCE PORT [FLUID] EE3 - INTENSIFIER PORT [AIR]
RETURN FORCE (AT 100 PSI): 210 LBS.

Model No.	Total Stroke (in.)	Power Stroke (in.)	A (in.)	B (in.)	C (in.)	Fluid Req'd (cu. in.)
Ratio 22:1						
8822-RH-.26-6AZ1	1-1/2	0.26	11-1/16	1-7/8	2-13/16	5
8822-RH-.26-8AZ1	2	0.26	12-1/16	2-3/8	3-5/16	6
8822-RH-.26-12AZ1	3	0.26	14-1/16	3-3/8	4-5/16	9
8822-RH-.26-16AZ1	4	0.26	16-1/16	4-3/8	5-5/16	13
8822-RH-.26-20AZ1	5	0.26	18-1/16	5-3/8	6-5/16	16
8822-RH-.26-24AZ1	6	0.26	20-1/16	6-3/8	7-5/16	19
Ratio 32:1						
8832-RH-.20-6AZ1	1-1/2	0.20	11-1/16	1-7/8	2-13/16	5
8832-RH-.20-8AZ1	2	0.20	12-1/16	2-3/8	3-5/16	6
8832-RH-.20-12AZ1	3	0.20	14-1/16	3-3/8	4-5/16	9
8832-RH-.20-16AZ1	4	0.20	16-1/16	4-3/8	5-5/16	13
8832-RH-.20-20AZ1	5	0.20	18-1/16	5-3/8	6-5/16	16
8832-RH-.20-24AZ1	6	0.20	20-1/16	6-3/8	7-5/16	19
Ratio 40:1						
8840-RH-.17-6AZ1	1-1/2	0.17	11-1/16	1-7/8	2-13/16	5
8840-RH-.17-8AZ1	2	0.17	12-1/16	2-3/8	3-5/16	6
8840-RH-.17-12AZ1	3	0.17	14-1/16	3-3/8	4-5/16	9
8840-RH-.17-16AZ1	4	0.17	16-1/16	4-3/8	5-5/16	13
8840-RH-.17-20AZ1	5	0.17	18-1/16	5-3/8	6-5/16	16
8840-RH-.17-24AZ1	6	0.17	20-1/16	6-3/8	7-5/16	19

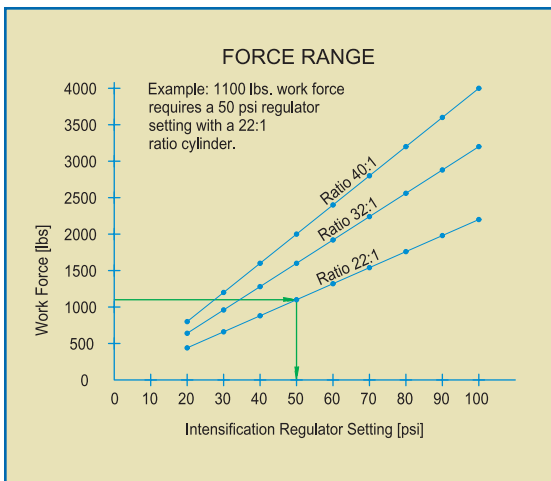

OHMA® Weld Cylinder
Bore: 2"
Ratio: 32:1
Mounting Style: Rear Hairpin
Power Stroke: 0.20"
Total Stroke: 2"
Front Block: Single Position
Seal Revision: Z1

8	8	32-	RH-	.20-	8	A	Z1
---	---	-----	-----	------	---	---	----

CODING EXAMPLE

Rod end style, port location, total stroke, ratio and power stroke modifications are available upon request. For details, consult with CenterLine.

2-5/8" BORE RH Mount

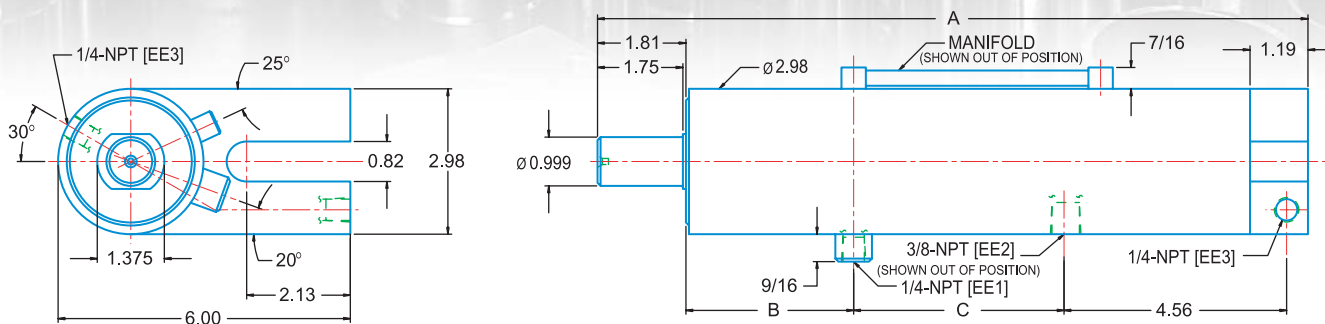

EE1 - RETURN PORT [AIR] EE2 - ADVANCE PORT [FLUID] EE3 - INTENSIFIER PORT [AIR]
RETURN FORCE (AT 100 PSI): 390 LBS.

Model No.	Total Stroke (in.)	Power Stroke (in.)	A (in.)	B (in.)	C (in.)	Fluid Req'd (cu. in.)
Ratio 37:1						
8105-37-RH-.35-6AZ1	1-1/2	0.35	11-9/16	1-15/16	2-13/16	8
8105-37-RH-.35-8AZ1	2	0.35	12-9/16	2-7/16	3-5/16	11
8105-37-RH-.35-12AZ1	3	0.35	14-9/16	3-7/16	4-5/16	16
8105-37-RH-.35-16AZ1	4	0.35	16-9/16	4-7/16	5-5/16	22
8105-37-RH-.35-20AZ1	5	0.35	18-9/16	5-7/16	6-5/16	27
8105-37-RH-.35-24AZ1	6	0.35	20-9/16	6-7/16	7-5/16	32
Ratio 49:1						
8105-49-RH-.27-6AZ1	1-1/2	0.27	11-9/16	1-15/16	2-13/16	8
8105-49-RH-.27-8AZ1	2	0.27	12-9/16	2-7/16	3-5/16	11
8105-49-RH-.27-12AZ1	3	0.27	14-9/16	3-7/16	4-5/16	16
8105-49-RH-.27-16AZ1	4	0.27	16-9/16	4-7/16	5-5/16	22
8105-49-RH-.27-20AZ1	5	0.27	18-9/16	5-7/16	6-5/16	27
8105-49-RH-.27-24AZ1	6	0.27	20-9/16	6-7/16	7-5/16	32
Ratio 66:1						
8105-66-RH-.20-6AZ1	1-1/2	0.20	11-9/16	1-15/16	2-13/16	8
8105-66-RH-.20-8AZ1	2	0.20	12-9/16	2-7/16	3-5/16	11
8105-66-RH-.20-12AZ1	3	0.20	14-9/16	3-7/16	4-5/16	16
8105-66-RH-.20-16AZ1	4	0.20	16-9/16	4-7/16	5-5/16	22
8105-66-RH-.20-20AZ1	5	0.20	18-9/16	5-7/16	6-5/16	27
8105-66-RH-.20-24AZ1	6	0.20	20-9/16	6-7/16	7-5/16	32

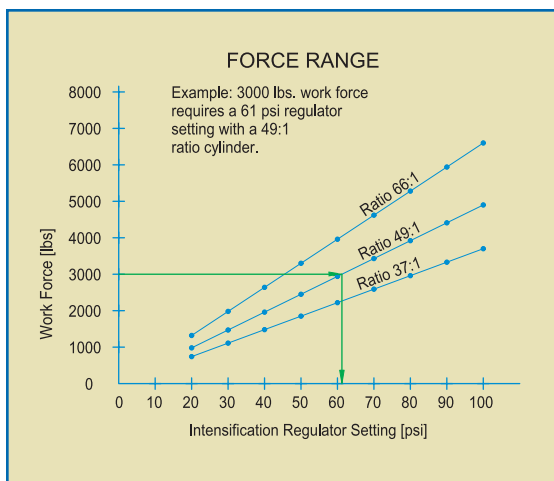

OHMA® Weld Cylinder
Bore: 2-5/8"
Ratio: 66:1
Mounting Style: Rear Hairpin
Power Stroke: 0.20"
Total Stroke: 1.50"
Front Block: Single Position
Seal Revision: Z1

8 105 -66- RH- .20- 6 A Z1
CODING EXAMPLE

Rod end style, port location, total stroke, ratio and power stroke modifications are available upon request. For details, consult with CenterLine.

1-3/4" BORE RC Mount

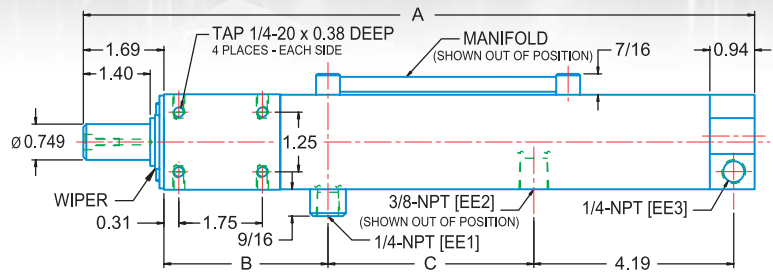
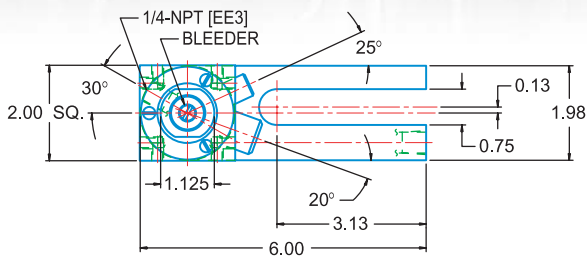

EE1 - RETURN PORT [AIR] EE2 - ADVANCE PORT [FLUID] EE3 - INTENSIFIER PORT [AIR]
RETURN FORCE (AT 100 PSI): 140 LBS.

Model No.	Total Stroke (in.)	Power Stroke (in.)	A (in.)	B (in.)	C (in.)	Fluid Req'd (cu. in.)
Ratio 13:1						
8713-RC-.29-6CZ1	1-1/2	0.29	11-1/16	1-15/16	2-13/16	4
8713-RC-.29-8CZ1	2	0.29	12-1/16	2-7/16	3-5/16	5
8713-RC-.29-12CZ1	3	0.29	14-1/16	3-7/16	4-5/16	7
8713-RC-.29-16CZ1	4	0.29	16-1/16	4-7/16	5-5/16	10
8713-RC-.29-20CZ1	5	0.29	18-1/16	5-7/16	6-5/16	12
8713-RC-.29-24CZ1	6	0.29	20-1/16	6-7/16	7-5/16	14
Ratio 19:1						
8719-RC-.25-6CZ1	1-1/2	0.25	11-1/16	1-15/16	2-13/16	4
8719-RC-.25-8CZ1	2	0.25	12-1/16	2-7/16	3-5/16	5
8719-RC-.25-12CZ1	3	0.25	14-1/16	3-7/16	4-5/16	7
8719-RC-.25-16CZ1	4	0.25	16-1/16	4-7/16	5-5/16	10
8719-RC-.25-20CZ1	5	0.25	18-1/16	5-7/16	6-5/16	12
8719-RC-.25-24CZ1	6	0.25	20-1/16	6-7/16	7-5/16	14

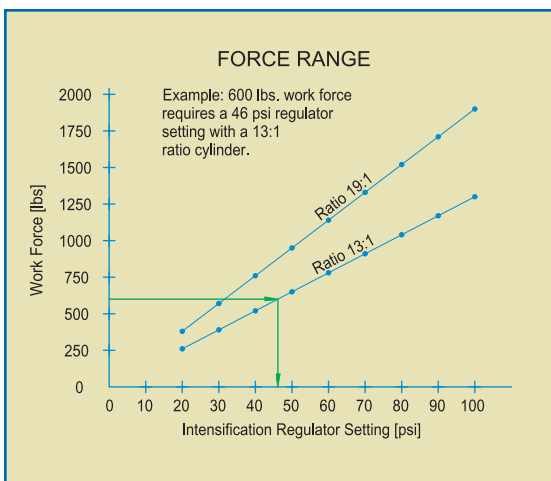

OHMA® Weld Cylinder
Bore: 1-3/4"
Ratio: 13:1
Mounting Style: Cubic Rear Hairpin
Power Stroke: 0.29"
Total Stroke: 3"
Front Block: Multi Position
Seal Revision: Z1

8	7	13-	RC-	.29-	12	C	Z1
---	---	-----	-----	------	----	---	----

CODING EXAMPLE

Rod end style, port location, total stroke, ratio and power stroke modifications are available upon request. For details, consult with CenterLine.

2" BORE RC Mount

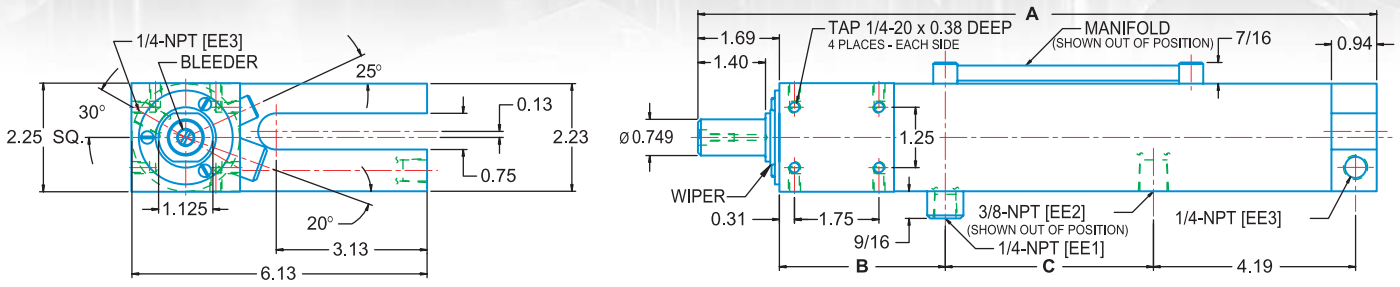

EE1 - RETURN PORT [AIR] EE2 - ADVANCE PORT [FLUID] EE3 - INTENSIFIER PORT [AIR]
RETURN FORCE (AT 100 PSI): 210 LBS.

Model No.	Total Stroke (in.)	Power Stroke (in.)	A (in.)	B (in.)	C (in.)	Fluid Req'd (cu. in.)
Ratio 22 : 1						
8822-RC-.26-6CZ1	1-1/2	0.26	11-1/16	1-15/16	2-13/16	5
8822-RC-.26-8CZ1	2	0.26	12-1/16	2-7/16	3-5/16	6
8822-RC-.26-12CZ1	3	0.26	14-1/16	3-7/16	4-5/16	9
8822-RC-.26-16CZ1	4	0.26	16-1/16	4-7/16	5-5/16	13
8822-RC-.26-20CZ1	5	0.26	18-1/16	5-7/16	6-5/16	16
8822-RC-.26-24CZ1	6	0.26	20-1/16	6-7/16	7-5/16	19
Ratio 32 : 1						
8832-RC-.20-6CZ1	1-1/2	0.20	11-1/16	1-15/16	2-13/16	5
8832-RC-.20-8CZ1	2	0.20	12-1/16	2-7/16	3-5/16	6
8832-RC-.20-12CZ1	3	0.20	14-1/16	3-7/16	4-5/16	9
8832-RC-.20-16CZ1	4	0.20	16-1/16	4-7/16	5-5/16	13
8832-RC-.20-20CZ1	5	0.20	18-1/16	5-7/16	6-5/16	16
8832-RC-.20-24CZ1	6	0.20	20-1/16	6-7/16	7-5/16	19
Ratio 40 : 1						
8840-RC-.17-6CZ1	1-1/2	0.17	11-1/16	1-15/16	2-13/16	5
8840-RC-.17-8CZ1	2	0.17	12-1/16	2-7/16	3-5/16	6
8840-RC-.17-12CZ1	3	0.17	14-1/16	3-7/16	4-5/16	9
8840-RC-.17-16CZ1	4	0.17	16-1/16	4-7/16	5-5/16	13
8840-RC-.17-20CZ1	5	0.17	18-1/16	5-7/16	6-5/16	16
8840-RC-.17-24CZ1	6	0.17	20-1/16	6-7/16	7-5/16	19

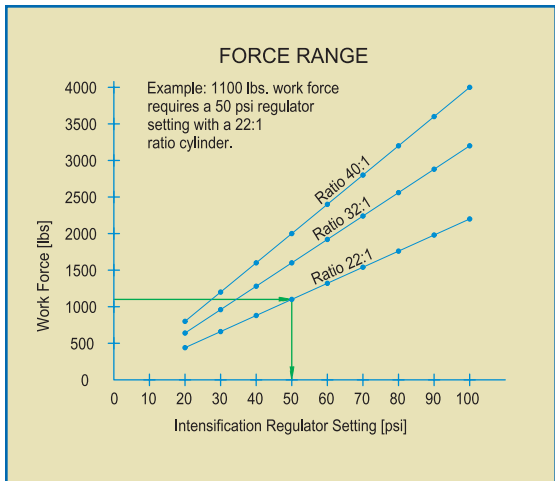

OHMA® Weld Cylinder
 Bore: 2"
 Ratio: 40:1
 Mounting Style: Cubic Rear Hairpin
 Power Stroke: 0.17"
 Total Stroke: 3"
 Front Block: Multi Position
 Seal Revision: Z1

8	8	40-	RC-	.17-	12	C	Z1
CODING EXAMPLE							

Rod end style, port location, total stroke, ratio and power stroke modifications are available upon request. For details, consult with CenterLine.

2-5/8" BORE RC Mount

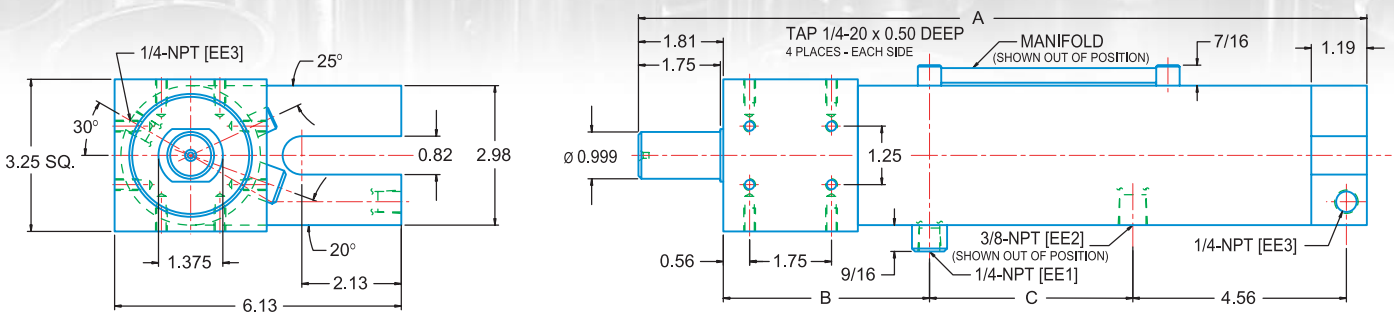

EE1 - RETURN PORT [AIR] EE2 - ADVANCE PORT [FLUID] EE3 - INTENSIFIER PORT [AIR]
RETURN FORCE (AT 100 PSI): 390 LBS.

Model No.	Total Stroke (in.)	Power Stroke (in.)	A (in.)	B (in.)	C (in.)	Fluid Req'd (cu. in.)
Ratio 37:1						
8105-37-RC-.35-6CZ1	1-1/2	0.35	14-1/16	4-13/32	2-27/32	8
8105-37-RC-.35-8CZ1	2	0.35	14-9/16	4-13/32	3-11/32	11
8105-37-RC-.35-12CZ1	3	0.35	15-9/16	4-13/32	4-11/32	16
8105-37-RC-.35-16CZ1	4	0.35	16-9/16	4-13/32	5-11/32	22
8105-37-RC-.35-20CZ1	5	0.35	18-9/16	5-13/32	6-11/32	27
8105-37-RC-.35-24CZ1	6	0.35	20-9/16	6-13/32	7-11/32	32
Ratio 49:1						
8105-49-RC-.27-6CZ1	1-1/2	0.27	14-1/16	4-13/32	2-27/32	8
8105-49-RC-.27-8CZ1	2	0.27	14-9/16	4-13/32	3-11/32	11
8105-49-RC-.27-12CZ1	3	0.27	15-9/16	4-13/32	4-11/32	16
8105-49-RC-.27-16CZ1	4	0.27	16-9/16	4-13/32	5-11/32	22
8105-49-RC-.27-20CZ1	5	0.27	18-9/16	5-13/32	6-11/32	27
8105-49-RC-.27-24CZ1	6	0.27	20-9/16	6-13/32	7-11/32	32
Ratio 66:1						
8105-66-RC-.20-6CZ1	1-1/2	0.20	14-1/16	4-13/32	2-27/32	8
8105-66-RC-.20-8CZ1	2	0.20	14-9/16	4-13/32	3-11/32	11
8105-66-RC-.20-12CZ1	3	0.20	15-9/16	4-13/32	4-11/32	16
8105-66-RC-.20-16CZ1	4	0.20	16-9/16	4-13/32	5-11/32	22
8105-66-RC-.20-20CZ1	5	0.20	18-9/16	5-13/32	6-11/32	27
8105-66-RC-.20-24CZ1	6	0.20	20-9/16	6-13/32	7-11/32	32

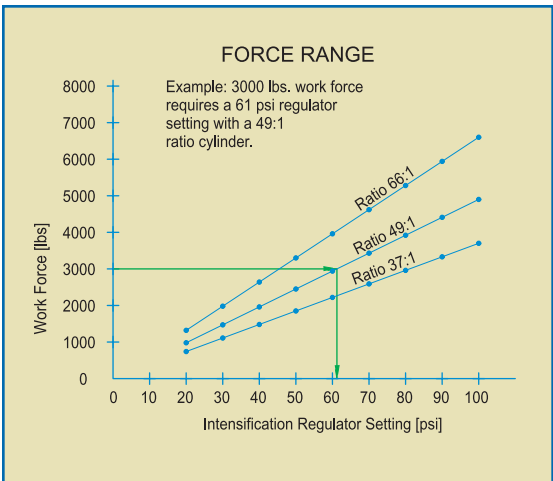

OHMA® Weld Cylinder
Bore: 2-5/8" Ratio: 66:1
Mounting Style: Cubic Rear Hairpin
Power Stroke: 0.20" Total Stroke: 1.50"
Front Block: Multi Position Seal Revision: Z1

8	105	-66-	RC-	.20-	6	C	Z1
CODING EXAMPLE							

Rod end style, port location, total stroke, ratio and power stroke modifications are available upon request. For details, consult with CenterLine.

1-3/4" BORE STUD Mount

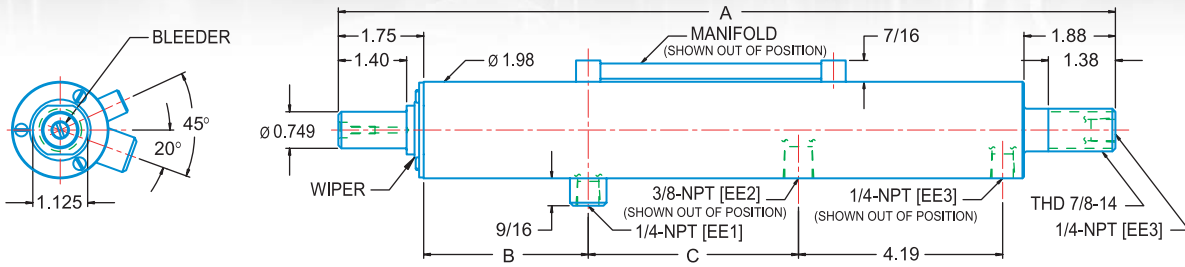

EE1 - RETURN PORT [AIR] EE2 - ADVANCE PORT [FLUID] EE3 - INTENSIFIER PORT [AIR]
 RETURN FORCE (AT 100 PSI): 140 LBS.

Model No.	Total Stroke (in.)	Power Stroke (in.)	A (in.)	B (in.)	C (in.)	D (in.)	Fluid Req'd (cu. in.)
Ratio 13:1							
8713-S-.29-6AZ1	1-1/2	0.29	12-15/16	1-7/8	1-7/8	2-13/16	4
8713-S-.29-8AZ1	2	0.29	13-15/16	2-3/8	2-3/8	3-5/16	5
8713-S-.29-12AZ1	3	0.29	15-15/16	3-3/8	3-3/8	4-5/16	7
8713-S-.29-16AZ1	4	0.29	17-15/16	4-3/8	4-3/8	5-5/16	10
8713-S-.29-20AZ1	5	0.29	19-15/16	5-3/8	5-3/8	6-5/16	12
8713-S-.29-24AZ1	6	0.29	21-15/16	6-3/8	6-3/8	7-5/16	14
Ratio 19:1							
8719-S-.25-6AZ1	1-1/2	0.25	12-15/16	1-7/8	1-7/8	2-13/16	4
8719-S-.25-8AZ1	2	0.25	13-15/16	2-3/8	2-3/8	3-5/16	5
8719-S-.25-12AZ1	3	0.25	15-15/16	3-3/8	3-3/8	4-5/16	7
8719-S-.25-16AZ1	4	0.25	17-15/16	4-3/8	4-3/8	5-5/16	10
8719-S-.25-20AZ1	5	0.25	19-15/16	5-3/8	5-3/8	6-5/16	12
8719-S-.25-24AZ1	6	0.25	21-15/16	6-3/8	6-3/8	7-5/16	14

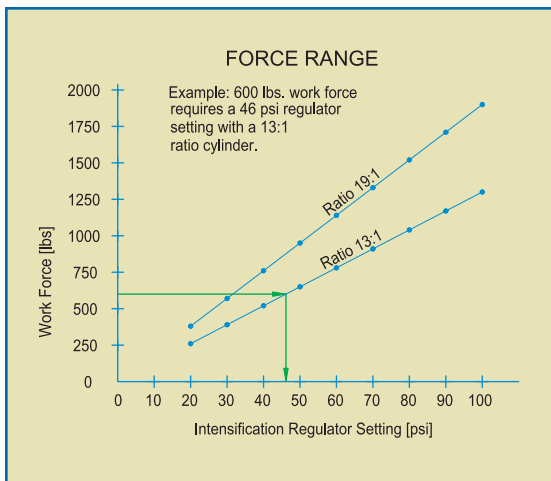

OHMA® Weld Cylinder
 Bore: 1-3/4"
 Ratio: 13:1
 Mounting Style: Stud
 Power Stroke: 0.29"
 Total Stroke: 6"
 Front Block: Single Position
 Seal Revision: Z1

8 7 13- S- .29- 24 A Z1
 CODING EXAMPLE

Rod end style, port location, total stroke, ratio and power stroke modifications are available upon request. For details, consult with CenterLine.

2" BORE STUD Mount

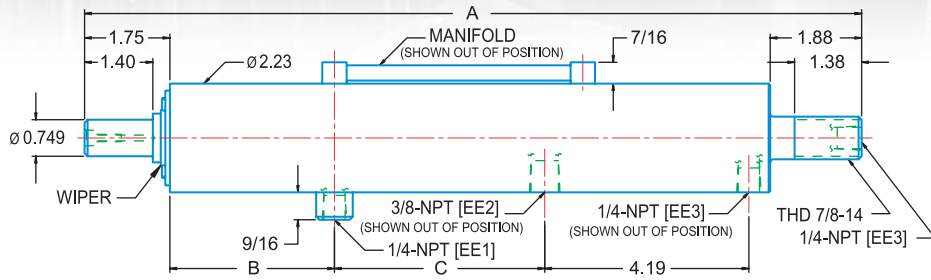
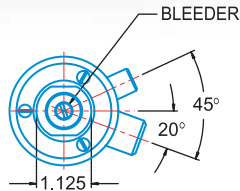

EE1 - RETURN PORT [AIR] EE2 - ADVANCE PORT [FLUID] EE3 - INTENSIFIER PORT [AIR]
RETURN FORCE (AT 100 PSI): 210 LBS.

Model No.	Total Stroke (in.)	Power Stroke (in.)	A (in.)	B (in.)	C (in.)	Fluid Req'd (cu. in.)
Ratio 22 : 1						
8822-S-.26-6AZ1	1-1/2	0.26	12-15/16	1-7/8	2-13/16	5
8822-S-.26-8AZ1	2	0.26	13-15/16	2-3/8	3-5/16	6
8822-S-.26-12AZ1	3	0.26	15-15/16	3-3/8	4-5/16	9
8822-S-.26-16AZ1	4	0.26	17-15/16	4-3/8	5-5/16	13
8822-S-.26-20AZ1	5	0.26	19-15/16	5-3/8	6-5/16	16
8822-S-.26-24AZ1	6	0.26	21-15/16	6-3/8	7-5/16	19
Ratio 32 : 1						
8832-S-.20-6AZ1	1-1/2	0.20	12-15/16	1-7/8	2-13/16	5
8832-S-.20-8AZ1	2	0.20	13-15/16	2-3/8	3-5/16	6
8832-S-.20-12AZ1	3	0.20	15-15/16	3-3/8	4-5/16	9
8832-S-.20-16AZ1	4	0.20	17-15/16	4-3/8	5-5/16	13
8832-S-.20-20AZ1	5	0.20	19-15/16	5-3/8	6-5/16	16
8832-S-.20-20AZ1	6	0.20	21-15/16	6-3/8	7-5/16	19
Ratio 40 : 1						
8840-S-.17-6AZ1	1-1/2	0.17	12-15/16	1-7/8	2-13/16	5
8840-S-.17-8AZ1	2	0.17	13-15/16	2-3/8	3-5/16	6
8840-S-.17-12AZ1	3	0.17	15-15/16	3-3/8	4-5/16	9
8840-S-.17-16AZ1	4	0.17	17-15/16	4-3/8	5-5/16	13
8840-S-.17-20AZ1	5	0.17	19-15/16	5-3/8	6-5/16	16
8840-S-.17-24AZ1	6	0.17	21-15/16	6-3/8	7-5/16	19

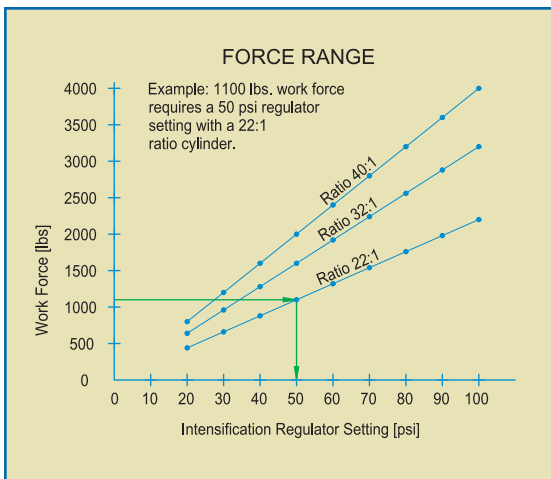

OHMA® Weld Cylinder
Bore: 2"
Ratio: 40:1
Mounting Style: Stud
Power Stroke: 0.17"
Total Stroke: 4"
Front Block: Single Position
Seal Revision: Z1

8	8	40-	S-	.17-	16	A	Z1
---	---	-----	----	------	----	---	----

CODING EXAMPLE

Rod end style, port location, total stroke, ratio and power stroke modifications are available upon request. For details, consult with CenterLine.

2-5/8" BORE STUD Mount

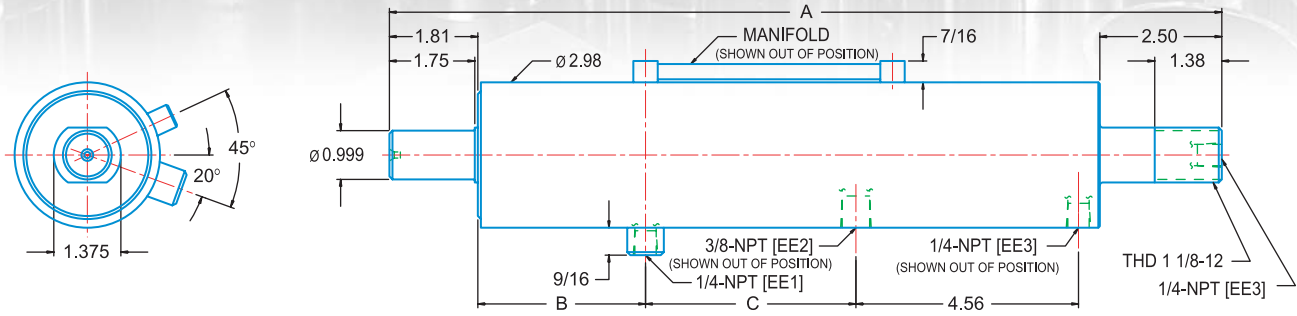

EE1 - RETURN PORT [AIR] EE2 - ADVANCE PORT [FLUID] EE3 - INTENSIFIER PORT [AIR]
RETURN FORCE (AT 100 PSI): 390 LBS.

Model No.	Total Stroke (in.)	Power Stroke (in.)	A (in.)	B (in.)	C (in.)	Fluid Req'd (cu. in.)
Ratio 37:1						
8105-37-S-.35-6AZ1	1-1/2	0.35	14-1/16	1-15/16	2-13/16	8
8105-37-S-.35-8AZ1	2	0.35	15-1/16	2-7/16	3-5/16	11
8105-37-S-.35-12AZ1	3	0.35	17-1/16	3-7/16	4-5/16	16
8105-37-S-.35-16AZ1	4	0.35	19-1/16	4-7/16	5-5/16	22
8105-37-S-.35-20AZ1	5	0.35	21-1/16	5-7/16	6-5/16	27
8105-37-S-.35-24AZ1	6	0.35	23-1/16	6-7/16	7-5/16	32
Ratio 49:1						
8105-49-S-.27-6AZ1	1-1/2	0.27	14-1/16	1-15/16	2-13/16	8
8105-49-S-.27-8AZ1	2	0.27	15-1/16	2-7/16	3-5/16	11
8105-49-S-.27-12AZ1	3	0.27	17-1/16	3-7/16	4-5/16	16
8105-49-S-.27-16AZ1	4	0.27	19-1/16	4-7/16	5-5/16	22
8105-49-S-.27-20AZ1	5	0.27	21-1/16	5-7/16	6-5/16	27
8105-49-S-.27-24AZ1	6	0.27	23-1/16	6-7/16	7-5/16	32
Ratio 66:1						
8105-66-S-.20-6AZ1	1-1/2	0.20	14-1/16	1-15/16	2-13/16	8
8105-66-S-.20-8AZ1	2	0.20	15-1/16	2-7/16	3-5/16	11
8105-66-S-.20-12AZ1	3	0.20	17-1/16	3-7/16	4-5/16	16
8105-66-S-.20-16AZ1	4	0.20	19-1/16	4-7/16	5-5/16	22
8105-66-S-.20-20AZ1	5	0.20	21-1/16	5-7/16	6-5/16	27
8105-66-S-.20-24AZ1	6	0.20	23-1/16	6-7/16	7-5/16	32

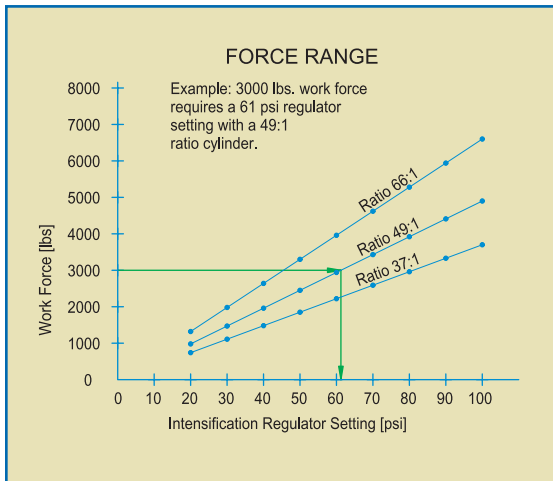

OHMA® Weld Cylinder
Bore: 2-5/8" Ratio: 49:1 Mounting Style: Stud
Power Stroke: 0.27" Total Stroke: 1.50" Front Block: Single Position
Seal Revision: Z1

8	105-	49-	S-	.27-	6	A	Z1
CODING EXAMPLE							

Rod end style, port location, total stroke, ratio and power stroke modifications are available upon request. For details, consult with CenterLine.

1-3/4" BORE FBL Mount

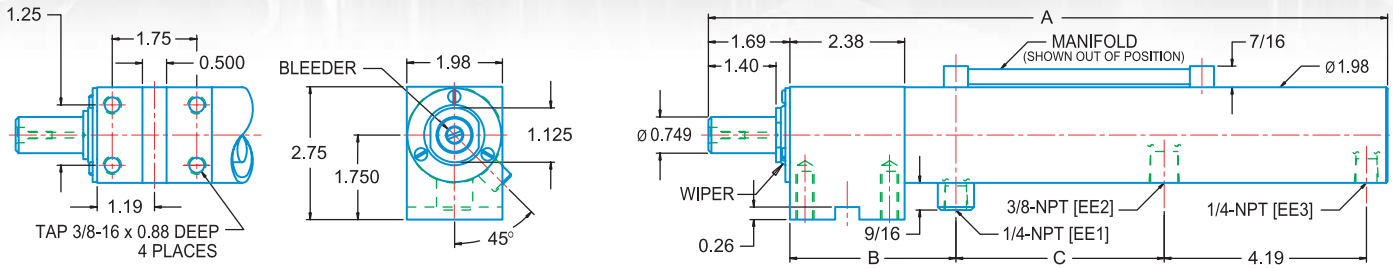

EE1 - RETURN PORT [AIR] EE2 - ADVANCE PORT [FLUID] EE3 - INTENSIFIER PORT [AIR]
RETURN FORCE (AT 100 PSI): 140 LBS.

Model No.	Total Stroke (in.)	Power Stroke (in.)	A (in.)	B (in.)	C (in.)	Fluid Req'd (cu. in.)
Ratio 13:1						
8713-FBL-.29-6CZ1	1-1/2	0.29	12-9/16	3-7/16	2-13/16	4
8713-FBL-.29-8CZ1	2	0.29	13-1/16	3-7/16	3-5/16	5
8713-FBL-.29-12CZ1	3	0.29	14-1/16	3-7/16	4-5/16	7
8713-FBL-.29-16CZ1	4	0.29	16-1/16	4-7/16	5-5/16	10
8713-FBL-.29-20CZ1	5	0.29	18-1/16	5-7/16	6-5/16	12
8713-FBL-.29-24CZ1	6	0.29	20-1/16	6-7/16	7-5/16	14
Ratio 19:1						
8719-FBL-.25-6CZ1	1-1/2	0.25	12-9/16	3-7/16	2-13/16	4
8719-FBL-.25-8CZ1	2	0.25	13-1/16	3-7/16	3-5/16	5
8719-FBL-.25-12CZ1	3	0.25	14-1/16	3-7/16	4-5/16	7
8719-FBL-.25-16CZ1	4	0.25	16-1/16	4-7/16	5-5/16	10
8719-FBL-.25-20CZ1	5	0.25	18-1/16	5-7/16	6-5/16	12
8719-FBL-.25-24CZ1	6	0.25	20-1/16	6-7/16	7-5/16	14

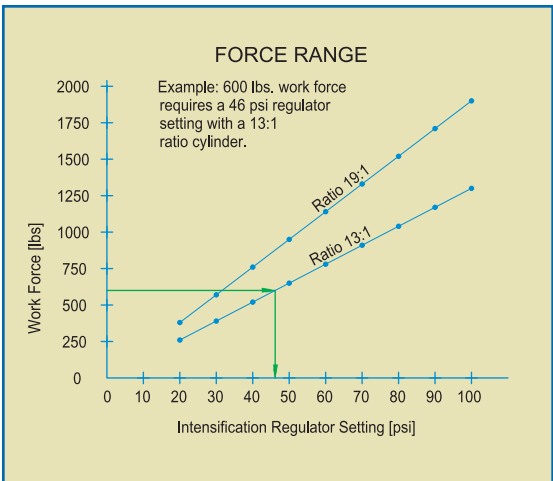

OHMA® Weld Cylinder
Bore: 1-3/4"
Ratio: 19:1
Mounting Style: Front Block
Power Stroke: 0.25"
Total Stroke: 5"
Front Block: Multi Position
Seal Revision: Z1

8	7	19-	FBL-	.25-	20	C	Z1
CODING EXAMPLE							

Rod end style, port location, total stroke, ratio and power stroke modifications are available upon request. For details, consult with CenterLine.

2" BORE FBL Mount

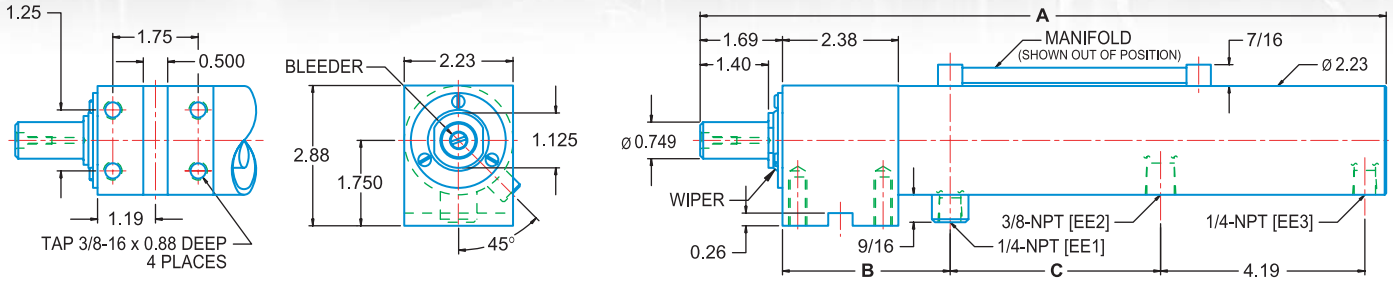

EE1 - RETURN PORT [AIR] EE2 - ADVANCE PORT [FLUID] EE3 - INTENSIFIER PORT [AIR]
RETURN FORCE (AT 100 PSI): 210 LBS.

Model No.	Total Stroke (in.)	Power Stroke (in.)	A (in.)	B (in.)	C (in.)	Fluid Req'd (cu. in.)
Ratio 22 : 1						
8822-FBL-.26-6CZ1	1-1/2	0.26	12-9/16	3-7/16	2-13/16	5
8822-FBL-.26-8CZ1	2	0.26	13-1/16	3-7/16	3-5/16	6
8822-FBL-.26-12CZ1	3	0.26	14-1/16	3-7/16	4-5/16	9
8822-FBL-.26-16CZ1	4	0.26	16-1/16	4-7/16	5-5/16	13
8822-FBL-.26-20CZ1	5	0.26	18-1/16	5-7/16	6-5/16	16
8822-FBL-.26-24CZ1	6	0.26	20-1/16	6-7/16	7-5/16	19
Ratio 32 : 1						
8832-FBL-.20-6CZ1	1-1/2	0.20	12-9/16	3-7/16	2-13/16	5
8832-FBL-.20-8CZ1	2	0.20	13-1/16	3-7/16	3-5/16	6
8832-FBL-.20-12CZ1	3	0.20	14-1/16	3-7/16	4-5/16	9
8832-FBL-.20-16CZ1	4	0.20	16-1/16	4-7/16	5-5/16	13
8832-FBL-.20-20CZ1	5	0.20	18-1/16	5-7/16	6-5/16	16
8832-FBL-.20-24CZ1	6	0.20	20-1/16	6-7/16	7-5/16	19
Ratio 40 : 1						
8840-FBL-.17-6CZ1	1-1/2	0.17	12-9/16	3-7/16	2-13/16	5
8840-FBL-.17-8CZ1	2	0.17	13-1/16	3-7/16	3-5/16	6
8840-FBL-.17-12CZ1	3	0.17	14-1/16	3-7/16	4-5/16	9
8840-FBL-.17-16CZ1	4	0.17	16-1/16	4-7/16	5-5/16	13
8840-FBL-.17-20CZ1	5	0.17	18-1/16	5-7/16	6-5/16	16
8840-FBL-.17-24CZ1	6	0.17	20-1/16	6-7/16	7-5/16	19

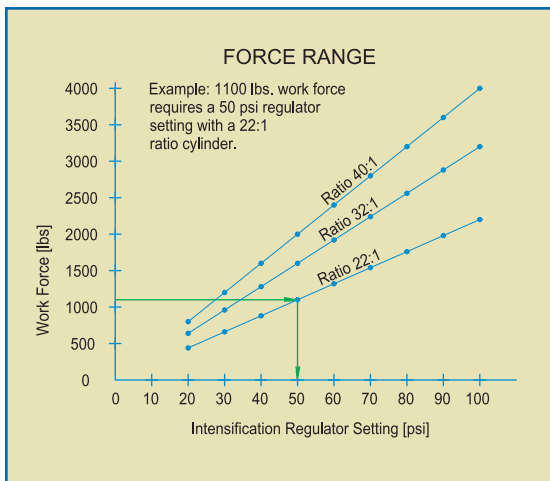

OHMA® Weld Cylinder
Bore: 2"
Ratio: 32:1
Mounting Style: Front Block
Power Stroke: 0.20"
Total Stroke: 5"
Front Block: Multi Position
Seal Revision: Z1

8 8 32- FBL- .20- 20 C Z1
CODING EXAMPLE

Rod end style, port location, total stroke, ratio and power stroke modifications are available upon request. For details, consult with CenterLine.

2-5/8" BORE FBL Mount

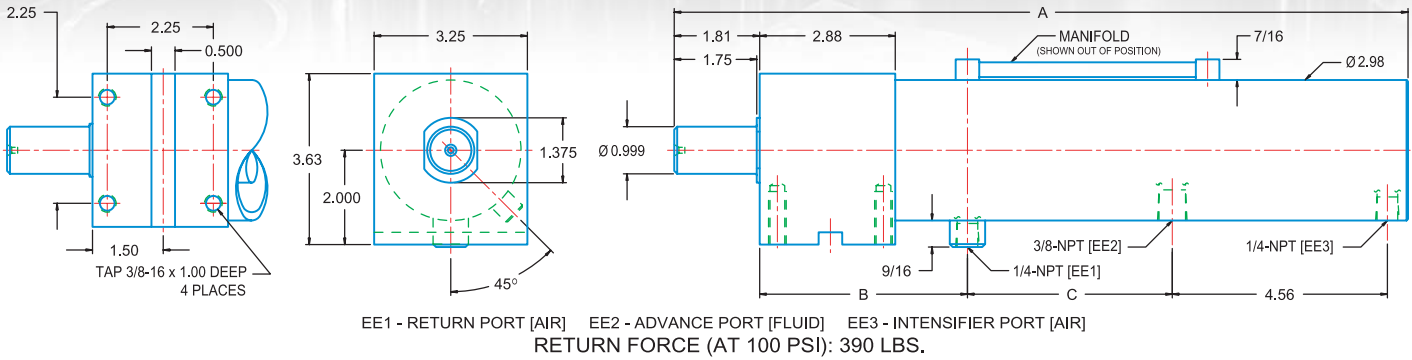

Model No.	Total Stroke (in.)	Power Stroke (in.)	A (in.)	B (in.)	C (in.)	Fluid Req'd (cu. in.)
Ratio 37:1						
8105-37-FBL-.35-6CZ1	1-1/2	0.35	14-1/16	4-13/32	2-27/32	8
8105-37-FBL-.35-8CZ1	2	0.35	14-9/16	4-13/32	3-11/32	11
8105-37-FBL-.35-12CZ1	3	0.35	15-9/16	4-13/32	4-11/32	16
8105-37-FBL-.35-16CZ1	4	0.35	16-9/16	4-13/32	5-11/32	22
8105-37-FBL-.35-20CZ1	5	0.35	18-9/16	5-13/32	6-11/32	27
8105-37-FBL-.35-24CZ1	6	0.35	20-9/16	6-13/32	7-11/32	32
Ratio 49:1						
8105-49-FBL-.27-6CZ1	1-1/2	0.27	14-1/16	4-13/32	2-27/32	8
8105-49-FBL-.27-8CZ1	2	0.27	14-9/16	4-13/32	3-11/32	11
8105-49-FBL-.27-12CZ1	3	0.27	15-9/16	4-13/32	4-11/32	16
8105-49-FBL-.27-16CZ1	4	0.27	16-9/16	4-13/32	5-11/32	22
8105-49-FBL-.27-20CZ1	5	0.27	18-9/16	5-13/32	6-11/32	27
8105-49-FBL-.27-24CZ1	6	0.27	20-9/16	6-13/32	7-11/32	32
Ratio 66:1						
8105-66-FBL-.20-6CZ1	1-1/2	0.20	14-1/16	4-13/32	2-27/32	8
8105-66-FBL-.20-8CZ1	2	0.20	14-9/16	4-13/32	3-11/32	11
8105-66-FBL-.20-12CZ1	3	0.20	15-9/16	4-13/32	4-11/32	16
8105-66-FBL-.20-16CZ1	4	0.20	16-9/16	4-13/32	5-11/32	22
8105-66-FBL-.20-20CZ1	5	0.20	18-9/16	5-13/32	6-11/32	27
8105-66-FBL-.20-24CZ1	6	0.20	20-9/16	6-13/32	7-11/32	32

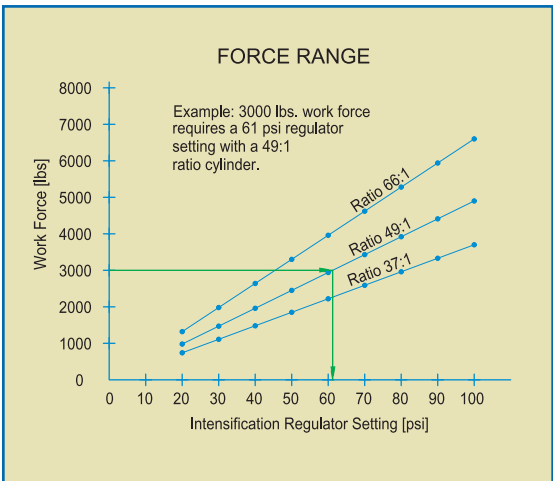

OHMA® Weld Cylinder
Bore: 2-5/8" Ratio: 66:1 Mounting Style: Front Block
Power Stroke: 0.20" Total Stroke: 6" Front Block: Multi Position
Seal Revision: Z1

8 105 -66- FBL -.20- 24 C Z1

CODING EXAMPLE

Rod end style, port location, total stroke, ratio and power stroke modifications are available upon request. For details, consult with CenterLine.

1-3/4" BORE FF Mount

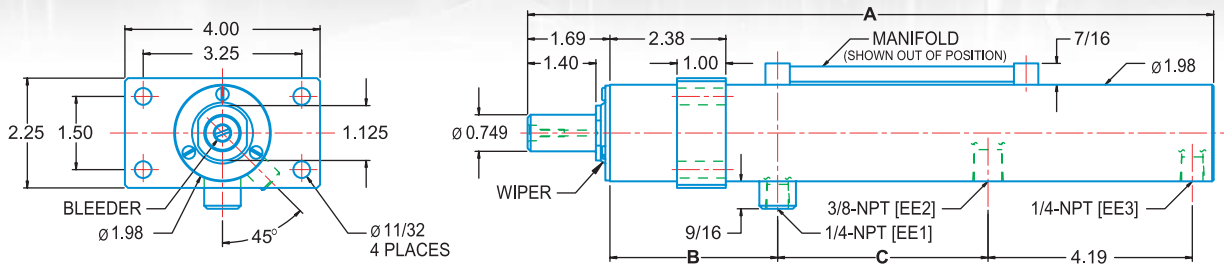

EE1 - RETURN PORT [AIR] EE2 - ADVANCE PORT [FLUID] EE3 - INTENSIFIER PORT [AIR]
RETURN FORCE (AT 100 PSI): 140 LBS.

Model No.	Total Stroke (in.)	Power Stroke (in.)	A (in.)	B (in.)	C (in.)	Fluid Req'd (cu. in.)
Ratio 13:1						
8713-FF-.29-6CZ1	1-1/2	0.29	12-9/16	3-7/16	2-13/16	4
8713-FF-.29-8CZ1	2	0.29	13-1/16	3-7/16	3-5/16	5
8713-FF-.29-12CZ1	3	0.29	14-1/16	3-7/16	4-5/16	7
8713-FF-.29-16CZ1	4	0.29	16-1/16	4-7/16	5-5/16	10
8713-FF-.29-20CZ1	5	0.29	18-1/16	5-7/16	6-5/16	12
8713-FF-.29-24CZ1	6	0.29	20-1/16	6-7/16	7-5/16	14
Ratio 19:1						
8719-FF-.25-6CZ1	1-1/2	0.25	12-9/16	3-7/16	2-13/16	4
8719-FF-.25-8CZ1	2	0.25	13-1/16	3-7/16	3-5/16	5
8719-FF-.25-12CZ1	3	0.25	14-1/16	3-7/16	4-5/16	7
8719-FF-.25-16CZ1	4	0.25	16-1/16	4-7/16	5-5/16	10
8719-FF-.25-20CZ1	5	0.25	18-1/16	5-7/16	6-5/16	12
8719-FF-.25-24CZ1	6	0.25	20-1/16	6-7/16	7-5/16	14

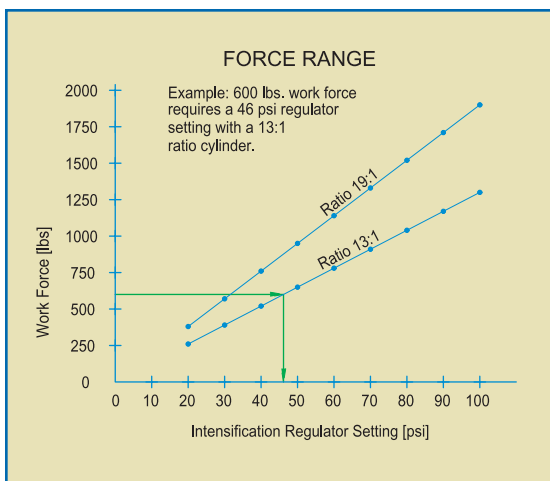

OHMA® Weld Cylinder
 Bore: 1-3/4"
 Ratio: 13:1
 Mounting Style: Front Flange
 Power Stroke: 0.29"
 Total Stroke: 2"
 Front Block: Multi Position
 Seal Revision: Z1

8	7	13-	FF-	.29-	8	C	Z1
CODING EXAMPLE							

Rod end style, port location, total stroke, ratio and power stroke modifications are available upon request. For details, consult with CenterLine.

2" BORE FF Mount

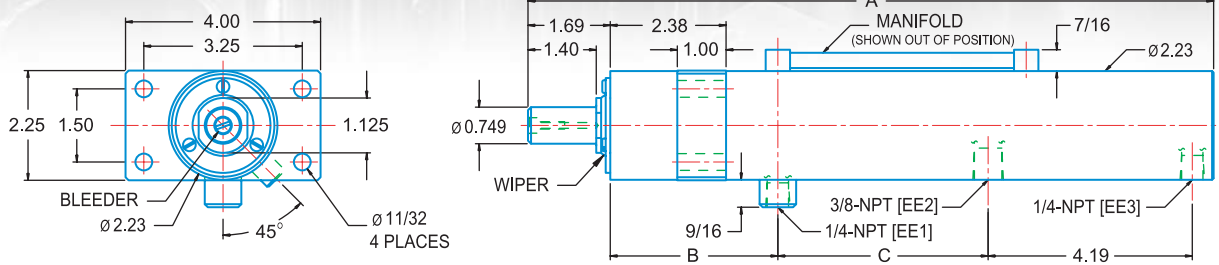

EE1 - RETURN PORT [AIR] EE2 - ADVANCE PORT [FLUID] EE3 - INTENSIFIER PORT [AIR]
 RETURN FORCE (AT 100 PSI): 210 LBS.

Model No.	Total Stroke (in.)	Power Stroke (in.)	A (in.)	B (in.)	C (in.)	Fluid Req'd (cu. in.)
Ratio 22:1						
8822-FF-.26-6CZ1	1-1/2	0.26	12-9/16	3-7/16	2-13/16	5
8822-FF-.26-8CZ1	2	0.26	13-1/16	3-7/16	3-5/16	6
8822-FF-.26-12CZ1	3	0.26	14-1/16	3-7/16	4-5/16	9
8822-FF-.26-16CZ1	4	0.26	16-1/16	4-7/16	5-5/16	13
8822-FF-.26-20CZ1	5	0.26	18-1/16	5-7/16	6-5/16	16
8822-FF-.26-24CZ1	6	0.26	20-1/16	6-7/16	7-5/16	19
Ratio 32:1						
8832-FF-.20-6CZ1	1-1/2	0.20	12-9/16	3-7/16	2-13/16	5
8832-FF-.20-8CZ1	2	0.20	13-1/16	3-7/16	3-5/16	6
8832-FF-.20-12CZ1	3	0.20	14-1/16	3-7/16	4-5/16	9
8832-FF-.20-16CZ1	4	0.20	16-1/16	4-7/16	5-5/16	13
8832-FF-.20-20CZ1	5	0.20	18-1/16	5-7/16	6-5/16	16
8832-FF-.20-24CZ1	6	0.20	20-1/16	6-7/16	7-5/16	19
Ratio 40:1						
8840-FF-.17-6CZ1	1-1/2	0.17	12-9/16	3-7/16	2-13/16	5
8840-FF-.17-8CZ1	2	0.17	13-1/16	3-7/16	3-5/16	6
8840-FF-.17-12CZ1	3	0.17	14-1/16	3-7/16	4-5/16	9
8840-FF-.17-16CZ1	4	0.17	16-1/16	4-7/16	5-5/16	13
8840-FF-.17-20CZ1	5	0.17	18-1/16	5-7/16	6-5/16	16
8840-FF-.17-24CZ1	6	0.17	20-1/16	6-7/16	7-5/16	19

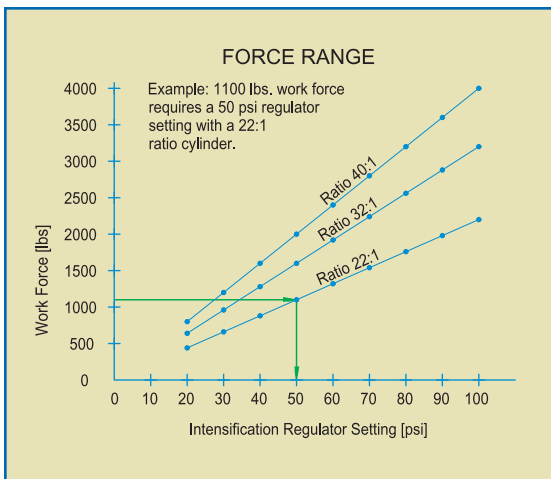

OHMA® Weld Cylinder
 Bore: 2"
 Ratio: 22:1
 Mounting Style: Front Flange
 Power Stroke: 0.26"
 Total Stroke: 5"
 Front Block: Multi Position
 Seal Revision: Z1

8	8	22-	FF-	.26-	20	C	Z1
---	---	-----	-----	------	----	---	----

CODING EXAMPLE

Rod end style, port location, total stroke, ratio and power stroke modifications are available upon request. For details, consult with CenterLine.

2-5/8" BORE FF Mount

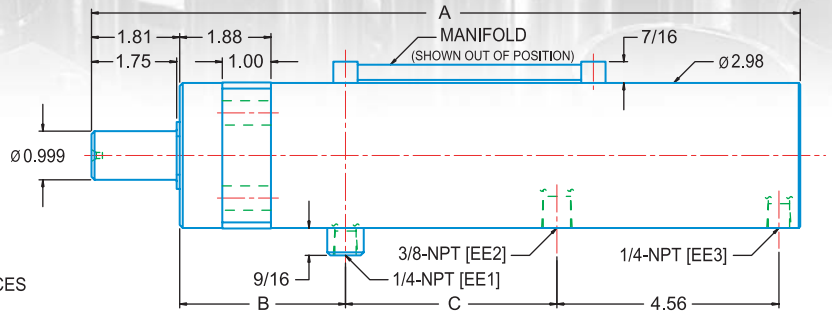
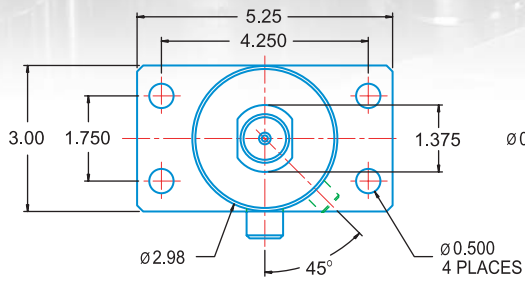

EE1 - RETURN PORT [AIR] EE2 - ADVANCE PORT [FLUID] EE3 - INTENSIFIER PORT [AIR]
RETURN FORCE (AT 100 PSI): 390 LBS.

Model No.	Total Stroke (in.)	Power Stroke (in.)	A (in.)	B (in.)	C (in.)	Fluid Req'd (cu. in.)
Ratio 37:1						
8105-37-FF-.35-6CZ1	1-1/2	0.35	13-1/16	3-13/32	2-27/32	8
8105-37-FF-.35-8CZ1	2	0.35	13-9/16	3-13/32	3-11/32	11
8105-37-FF-.35-12CZ1	3	0.35	14-9/16	3-13/32	4-11/32	16
8105-37-FF-.35-16CZ1	4	0.35	16-9/16	4-13/32	5-11/32	22
8105-37-FF-.35-20CZ1	5	0.35	18-9/16	5-13/32	6-11/32	27
8105-37-FF-.35-24CZ1	6	0.35	20-9/16	6-13/32	7-11/32	32
Ratio 49:1						
8105-49-FF-.27-6CZ1	1-1/2	0.27	13-1/16	3-13/32	2-27/32	8
8105-49-FF-.27-8CZ1	2	0.27	13-9/16	3-13/32	3-11/32	11
8105-49-FF-.27-12CZ1	3	0.27	14-9/16	3-13/32	4-11/32	16
8105-49-FF-.27-16CZ1	4	0.27	16-9/16	4-13/32	5-11/32	22
8105-49-FF-.27-20CZ1	5	0.27	18-9/16	5-13/32	6-11/32	27
8105-49-FF-.27-24CZ1	6	0.27	20-9/16	6-13/32	7-11/32	32
Ratio 66:1						
8105-66-FF-.20-6CZ1	1-1/2	0.20	13-1/16	3-13/32	2-27/32	8
8105-66-FF-.20-8CZ1	2	0.20	13-9/16	3-13/32	3-11/32	11
8105-66-FF-.20-12CZ1	3	0.20	14-9/16	3-13/32	4-11/32	16
8105-66-FF-.20-16CZ1	4	0.20	16-9/16	4-13/32	5-11/32	22
8105-66-FF-.20-20CZ1	5	0.20	18-9/16	5-13/32	6-11/32	27
8105-66-FF-.20-24CZ1	6	0.20	20-9/16	6-13/32	7-11/32	32

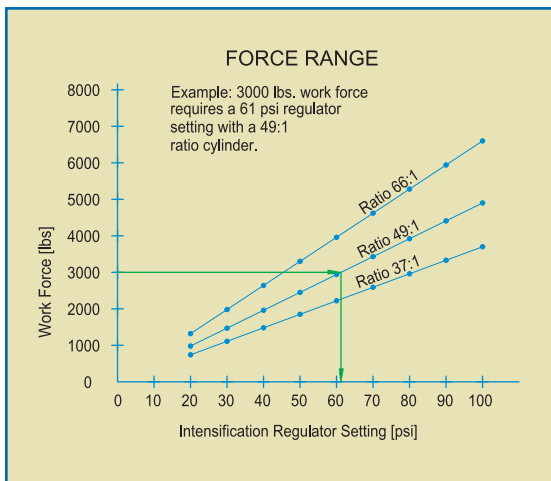

OHMA® Weld Cylinder
Bore: 2-5/8"
Ratio: 49:1
Mounting Style: Front Flange
Power Stroke: 0.27"
Total Stroke: 2"
Front Block: Multi Position
Seal Revision: Z1

8 105- 49- FF- .27- 8 C Z1
CODING EXAMPLE

Rod end style, port location, total stroke, ratio and power stroke modifications are available upon request. For details, consult with CenterLine.

1-3/4" BORE FNP Mount

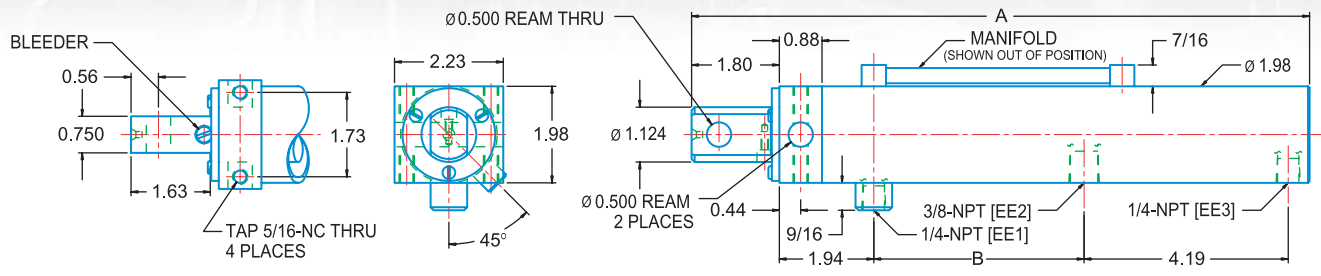

EE1 - RETURN PORT [AIR] EE2 - ADVANCE PORT [FLUID] EE3 - INTENSIFIER PORT [AIR]
 RETURN FORCE (AT 100 PSI): 140 LBS.

Model No.	Total Stroke (in.)	Power Stroke (in.)	A (in.)	B (in.)	Fluid Req'd (cu. in.)
Ratio 13:1					
8713-FNP-.29-6CZ1	1-1/2	0.29	11-3/16	2-13/16	4
8713-FNP-.29-8CZ1	2	0.29	11-11/16	3-5/16	5
8713-FNP-.29-12CZ1	3	0.29	12-11/16	4-5/16	7
8713-FNP-.29-16CZ1	4	0.29	13-11/16	5-5/16	10
8713-FNP-.29-20CZ1	5	0.29	14-11/16	6-5/16	12
8713-FNP-.29-24CZ1	6	0.29	15-11-16	7-5/16	14
Ratio 19:1					
8719-FNP-.25-6CZ1	1-1/2	0.25	11-3/16	2-13/16	4
8719-FNP-.25-8CZ1	2	0.25	11-11/16	3-5/16	5
8719-FNP-.25-12CZ1	3	0.25	12-11/16	4-5/16	7
8719-FNP-.25-16CZ1	4	0.25	13-11/16	5-5/16	10
8719-FNP-.25-20CZ1	5	0.25	14-11/16	6-5/16	12
8719-FNP-.25-24CZ1	6	0.25	15-11/16	7-5/16	14

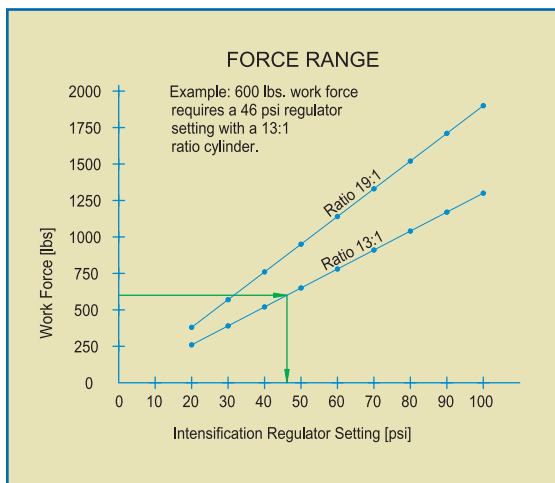

OHMA® Weld Cylinder
 Bore: 1-3/4"
 Ratio: 19:1
 Mounting Style: Front Nose Pivot
 Power Stroke: 0.25"
 Total Stroke: 6"
 Front Block: Multi Position
 Seal Revision: Z1

8	7	19-	FNP-	.25-	24	C	Z1
---	---	-----	------	------	----	---	----

CODING EXAMPLE

Rod end style, port location, total stroke, ratio and power stroke modifications are available upon request. For details, consult with CenterLine.

2" BORE FNP Mount

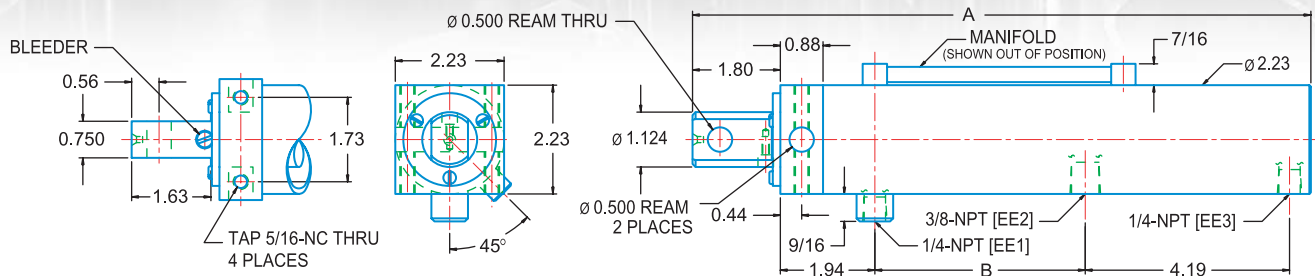

EE1 - RETURN PORT [AIR] EE2 - ADVANCE PORT [FLUID] EE3 - INTENSIFIER PORT [AIR]
RETURN FORCE (AT 100 PSI): 210 LBS.

Model No.	Total Stroke (in.)	Power Stroke (in.)	A (in.)	B (in.)	Fluid Req'd (cu. in.)
Ratio 22 : 1					
8822-FNP-.26-6CZ1	1-1/2	0.26	11-3/16	2-13/16	5
8822-FNP-.26-8CZ1	2	0.26	11-11/16	3-5/16	6
8822-FNP-.26-12CZ1	3	0.26	12-11/16	4-5/16	9
8822-FNP-.26-16CZ1	4	0.26	13-11/16	5-5/16	13
8822-FNP-.26-20CZ1	5	0.26	14-11/16	6-5/16	16
8822-FNP-.26-24CZ1	6	0.26	15-11/16	7-5/16	19
Ratio 32 : 1					
8832-FNP-.20-6CZ1	1-1/2	0.20	11-3/16	2-13/16	5
8832-FNP-.20-8CZ1	2	0.20	11-11/16	3-5/16	6
8832-FNP-.20-12CZ1	3	0.20	12-11/16	4-5/16	9
8832-FNP-.20-16CZ1	4	0.20	13-11/16	5-5/16	13
8832-FNP-.20-20CZ1	5	0.20	14-11/16	6-5/16	16
8832-FNP-.20-24CZ1	6	0.20	15-11/16	7-5/16	19
Ratio 40 : 1					
8840-FNP-.17-6CZ1	1-1/2	0.17	11-3/16	2-13/16	5
8840-FNP-.17-8CZ1	2	0.17	11-11/16	3-5/16	6
8840-FNP-.17-12CZ1	3	0.17	12-11/16	4-5/16	9
8840-FNP-.17-16CZ1	4	0.17	13-11/16	5-5/16	13
8840-FNP-.17-20CZ1	5	0.17	14-11/16	6-5/16	16
8840-FNP-.17-24CZ1	6	0.17	15-11/16	7-5/16	19

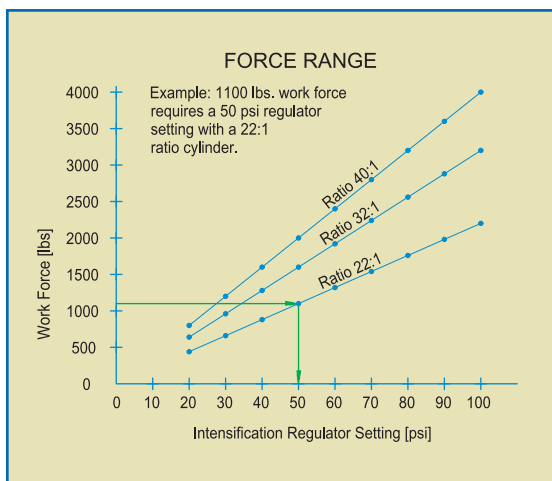

OHMA® Weld Cylinder
Bore: 2"
Ratio: 40:1
Mounting Style: Front Nose Pivot
Power Stroke: 0.17"
Total Stroke: 4"
Front Block: Multi Position
Seal Revision: Z1

8 8 40- FNP- .17- 16 C Z1

CODING EXAMPLE

Rod end style, port location, total stroke, ratio and power stroke modifications are available upon request. For details, consult with CenterLine.

2-5/8" BORE FNP Mount

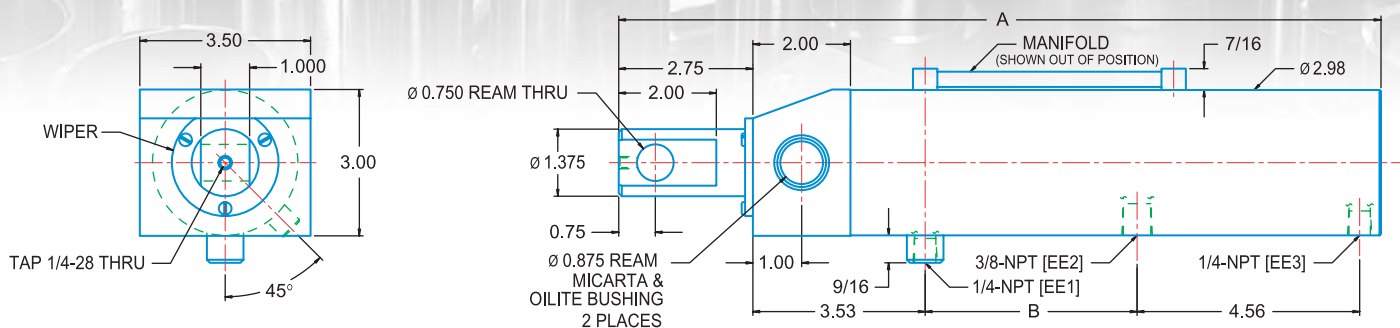

EE1 - RETURN PORT [AIR] EE2 - ADVANCE PORT [FLUID] EE3 - INTENSIFIER PORT [AIR]
RETURN FORCE (AT 100 PSI): 390 LBS.

Model No.	Total Stroke (in.)	Power Stroke (in.)	A (in.)	B (in.)	Fluid Req'd (cu. in.)
Ratio 37:1					
8105-37-FNP-.35-6CZ1	1-1/2	0.35	14-1/18	2-27/32	8
8105-37-FNP-.35-8CZ1	2	0.35	14-5/8	3-11/32	11
8105-37-FNP-.35-12CZ1	3	0.35	15-5/8	4-11/32	16
8105-37-FNP-.35-16CZ1	4	0.35	16-5/8	5-11/32	22
8105-37-FNP-.35-20CZ1	5	0.35	17-5/8	6-11/32	27
8105-37-FNP-.35-24CZ1	6	0.35	18-5/8	7-11/32	32
Ratio 49:1					
8105-49-FNP-.35-6CZ1	1-1/2	0.27	14-1/18	2-27/32	8
8105-49-FNP-.35-8CZ1	2	0.27	14-5/8	3-11/32	11
8105-49-FNP-.35-12CZ1	3	0.27	15-5/8	4-11/32	16
8105-49-FNP-.35-16CZ1	4	0.27	16-5/8	5-11/32	22
8105-49-FNP-.35-20CZ1	5	0.27	17-5/8	6-11/32	27
8105-49-FNP-.35-24CZ1	6	0.27	18-5/8	7-11/32	32
Ratio 66:1					
8105-66-FNP-.20-6CZ1	1-1/2	0.20	14-1/18	2-27/32	8
8105-66-FNP-.20-8CZ1	2	0.20	14-5/8	3-11/32	11
8105-66-FNP-.20-12CZ1	3	0.20	15-5/8	4-11/32	16
8105-66-FNP-.20-16CZ1	4	0.20	16-5/8	5-11/32	22
8105-66-FNP-.20-20CZ1	5	0.20	17-5/8	6-11/32	27
8105-66-FNP-.20-24CZ1	6	0.20	18-5/8	7-11/32	32

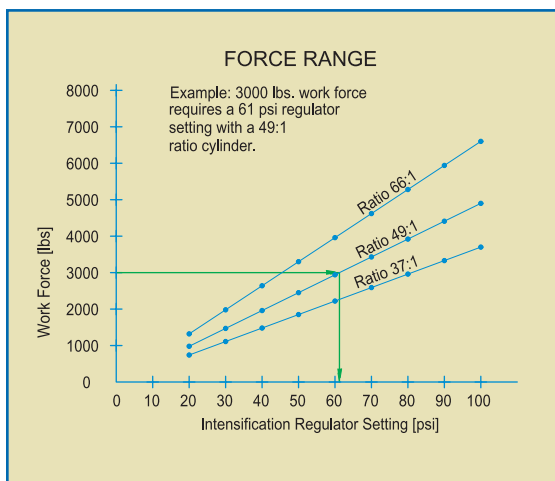

OHMA® Weld Cylinder
Bore: 2-5/8"
Ratio: 66:1
Mounting Style: Front Nose Pivot
Power Stroke: 0.20"
Total Stroke: 2"
Front Block: Multi Position
Seal Revision: Z1

8 105- 66- FNP- .20- 8 C Z1
CODING EXAMPLE

Rod end style, port location, total stroke, ratio and power stroke modifications are available upon request. For details, consult with CenterLine.

1-3/4" BORE PIN Mount

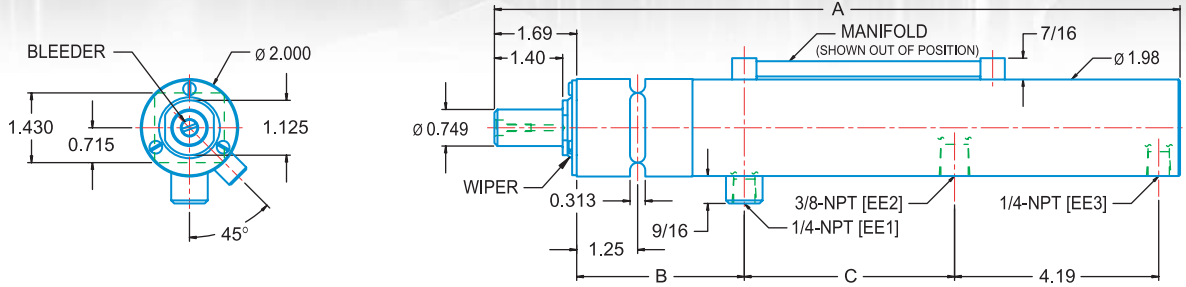

EE1 - RETURN PORT [AIR] EE2 - ADVANCE PORT [FLUID] EE3 - INTENSIFIER PORT [AIR]
RETURN FORCE (AT 100 PSI): 140 LBS.

Model No.	Total Stroke (in.)	Power Stroke (in.)	A (in.)	B (in.)	C (in.)	Fluid Req'd (cu. in.)
Ratio 13:1						
8713-PIN-.29-6CZ1	1-1/2	0.29	12-9/16	3-7/16	2-13/16	4
8713-PIN-.29-8CZ1	2	0.29	13-1/16	3-7/16	3-5/16	5
8713-PIN-.29-12CZ1	3	0.29	14-1/16	3-7/16	4-5/16	7
8713-PIN-.29-16CZ1	4	0.29	16-1/16	4-7/16	5-5/16	10
8713-PIN-.29-20CZ1	5	0.29	18-1/16	5-7/16	6-5/16	12
8713-PIN-.29-24CZ1	6	0.29	20-1/16	6-7/16	7-5/16	14
Ratio 19:1						
8719-PIN-.25-6CZ1	1-1/2	0.25	12-9/16	3-7/16	2-13/16	4
8719-PIN-.25-8CZ1	2	0.25	13-1/16	3-7/16	3-5/16	5
8719-PIN-.25-12CZ1	3	0.25	14-1/16	3-7/16	4-5/16	7
8719-PIN-.25-16CZ1	4	0.25	16-1/16	4-7/16	5-5/16	10
8719-PIN-.25-20CZ1	5	0.25	18-1/16	5-7/16	6-5/16	12
8719-PIN-.25-24CZ1	6	0.25	20-1/16	6-7/16	7-5/16	14

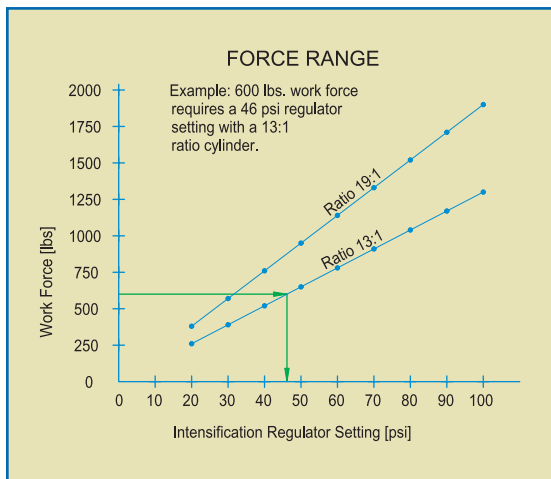

OHMA® Weld Cylinder
 Bore: 1-3/4"
 Ratio: 13:1
 Mounting Style: Pin Mount
 Power Stroke: 0.29"
 Total Stroke: 2"
 Front Block: Multi Position
 Seal Revision: Z1

8 7 13- PIN- .29- 8 C Z1
CODING EXAMPLE

Rod end style, port location, total stroke, ratio and power stroke modifications are available upon request. For details, consult with CenterLine.

2" BORE PIN Mount

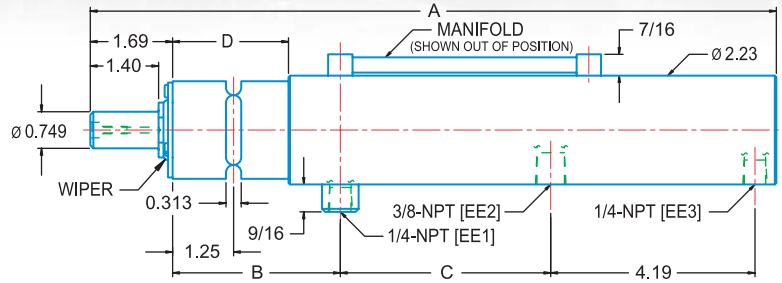
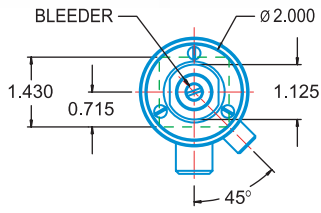

EE1 - RETURN PORT [AIR] EE2 - ADVANCE PORT [FLUID] EE3 - INTENSIFIER PORT [AIR]
RETURN FORCE (AT 100 PSI): 210 LBS.

Model No.	Total Stroke (in.)	Power Stroke (in.)	A (in.)	B (in.)	C (in.)	D (in.)	Fluid Req'd (cu. in.)
Ratio 22:1							
8822-PIN-.26-6CZ1	1-1/2	0.26	12-9/16	3-7/16	2-13/16	2-3/8	5
8822-PIN-.26-8CZ1	2	0.26	13-1/16	3-7/16	3-5/16	2-3/8	6
8822-PIN-.26-12CZ1	3	0.26	14-1/16	3-7/16	4-5/16	2-3/8	9
8822-PIN-.26-16CZ1	4	0.26	16-1/16	4-7/16	5-5/16	2-7/16	13
8822-PIN-.26-20CZ1	5	0.26	18-1/16	5-7/16	6-5/16	2-7/16	16
8822-PIN-.26-24CZ1	6	0.26	20-1/16	6-7/16	7-5/16	2-7/16	19
Ratio 32:1							
8832-PIN-.20-6CZ1	1-1/2	0.20	12-9/16	3-7/16	2-13/16	2-3/8	5
8832-PIN-.20-8CZ1	2	0.20	13-1/16	3-7/16	3-5/16	2-3/8	6
8832-PIN-.20-12CZ1	3	0.20	14-1/16	3-7/16	4-5/16	2-3/8	9
8832-PIN-.20-16CZ1	4	0.20	16-1/16	4-7/16	5-5/16	2-7/16	13
8832-PIN-.20-20CZ1	5	0.20	18-1/16	5-7/16	6-5/16	2-7/16	16
8832-PIN-.20-24CZ1	6	0.20	20-1/16	6-7/16	7-5/16	2-7/16	19
Ratio 40:1							
8840-PIN-.17-6CZ1	1-1/2	0.17	12-9/16	3-7/16	2-13/16	2-3/8	5
8840-PIN-.17-8CZ1	2	0.17	13-1/16	3-7/16	3-5/16	2-3/8	6
8840-PIN-.17-12CZ1	3	0.17	14-1/16	3-7/16	4-5/16	2-3/8	9
8840-PIN-.17-16CZ1	4	0.17	16-1/16	4-7/16	5-5/16	2-7/16	13
8840-PIN-.17-20CZ1	5	0.17	18-1/16	5-7/16	6-5/16	2-7/16	16
8840-PIN-.17-24CZ1	6	0.17	20-1/16	6-7/16	7-5/16	2-7/16	19

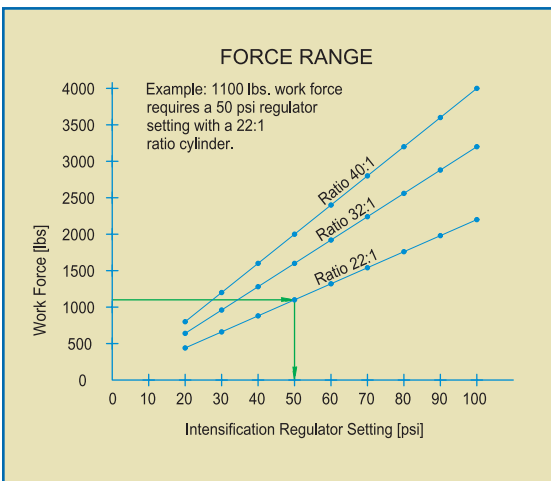

OHMA® Weld Cylinder
Bore: 2"
Ratio: 40:1
Mounting Style: Pin Mount
Power Stroke: 0.17"
Total Stroke: 3"
Front Block: Multi Position
Seal Revision: Z1

8	8	40-	PIN-	.17-	12	C	Z1
---	---	-----	------	------	----	---	----

CODING EXAMPLE

Rod end style, port location, total stroke, ratio and power stroke modifications are available upon request. For details, consult with CenterLine.

1-3/4" BORE FD Mount

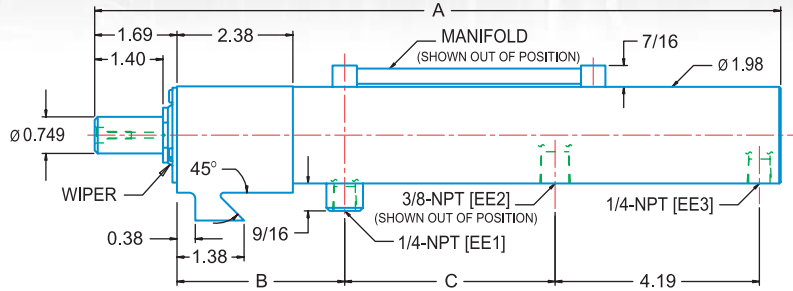
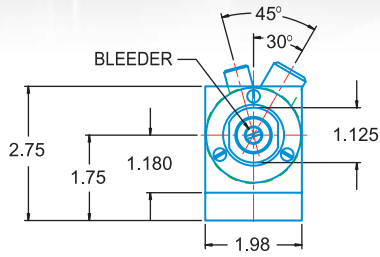

EE1 - RETURN PORT [AIR] EE2 - ADVANCE PORT [FLUID] EE3 - INTENSIFIER PORT [AIR]
RETURN FORCE (AT 100 PSI): 140 LBS.

Model No.	Total Stroke (in.)	Power Stroke (in.)	A (in.)	B (in.)	C (in.)	Fluid Req'd (cu. in.)
Ratio 13:1						
8713-FD-.29-6CZ1	1-1/2	0.29	12-9/16	3-7/16	2-13/16	4
8713-FD-.29-8CZ1	2	0.29	13-1/16	3-7/16	3-5/16	5
8713-FD-.29-12CZ1	3	0.29	14-1/16	3-7/16	4-5/16	7
8713-FD-.29-16CZ1	4	0.29	16-1/16	4-7/16	5-5/16	10
8713-FD-.29-20CZ1	5	0.29	18-1/16	5-7/16	6-5/16	12
8713-FD-.29-24CZ1	6	0.29	20-1/16	6-7/16	7-5/16	14
Ratio 19:1						
8719-FD-.25-6CZ1	1-1/2	0.25	12-9/16	3-7/16	2-13/16	4
8719-FD-.25-8CZ1	2	0.25	13-1/16	3-7/16	3-5/16	5
8719-FD-.25-12CZ1	3	0.25	14-1/16	3-7/16	4-5/16	7
8719-FD-.25-16CZ1	4	0.25	16-1/16	4-7/16	5-5/16	10
8719-FD-.25-20CZ1	5	0.25	18-1/16	5-7/16	6-5/16	12
8719-FD-.25-24CZ1	6	0.25	20-1/16	6-7/16	7-5/16	14

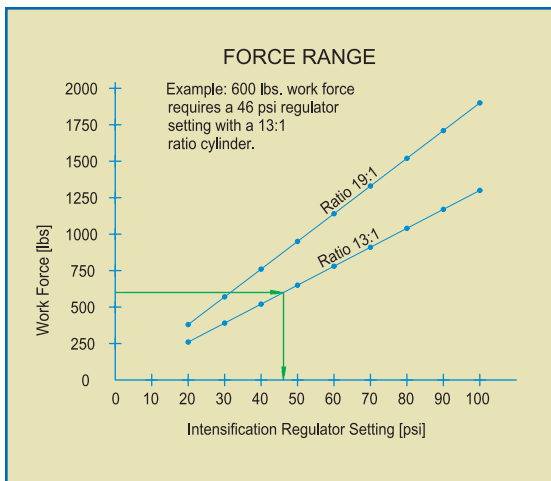

OHMA® Weld Cylinder
Bore: 1-3/4" Ratio: 19:1 Mounting Style: Front Dovetail
Power Stroke: 0.25" Total Stroke: 4" Front Block: Multi Position
Seal Revision: Z1

8 7 19- FD -.25 -16 C Z1
CODING EXAMPLE

Rod end style, port location, total stroke, ratio and power stroke modifications are available upon request. For details, consult with CenterLine.

2" BORE FD Mount

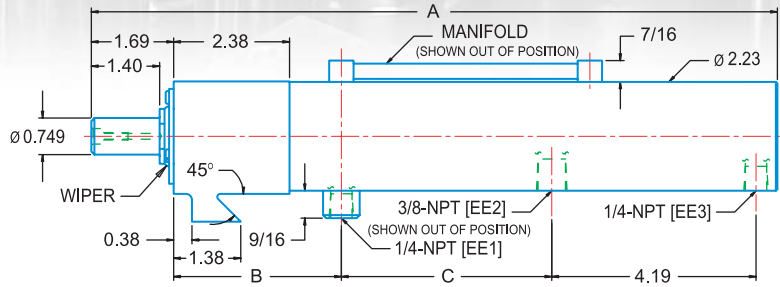
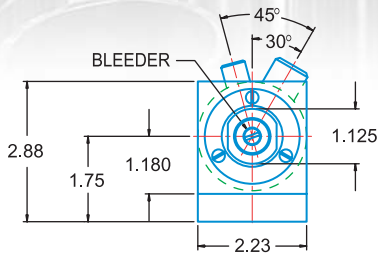

EE1 - RETURN PORT [AIR] EE2 - ADVANCE PORT [FLUID] EE3 - INTENSIFIER PORT [AIR]
 RETURN FORCE (AT 100 PSI): 210 LBS.

Model No.	Total Stroke (in.)	Power Stroke (in.)	A (in.)	B (in.)	C (in.)	Fluid Req'd (cu. in.)
Ratio 22 : 1						
8822-FD-.26-6CZ1	1-1/2	0.26	12-9/16	3-7/16	2-13/16	5
8822-FD-.26-8CZ1	2	0.26	13-1/16	3-7/16	3-5/16	6
8822-FD-.26-12CZ1	3	0.26	14-1/16	3-7/16	4-5/16	9
8822-FD-.26-16CZ1	4	0.26	16-1/16	4-7/16	5-5/16	13
8822-FD-.26-20CZ1	5	0.26	18-1/16	5-7/16	6-5/16	16
8822-FD-.26-24CZ1	6	0.26	20-1/16	6-7/16	7-5/16	19
Ratio 32 : 1						
8832-FD-.20-6CZ1	1-1/2	0.20	12-9/16	3-7/16	2-13/16	5
8832-FD-.20-8CZ1	2	0.20	13-1/16	3-7/16	3-5/16	6
8832-FD-.20-12CZ1	3	0.20	14-1/16	3-7/16	4-5/16	9
8832-FD-.20-16CZ1	4	0.20	16-1/16	4-7/16	5-5/16	13
8832-FD-.20-20CZ1	5	0.20	18-1/16	5-7/16	6-5/16	16
8832-FD-.20-24CZ1	6	0.20	20-1/16	6-7/16	7-5/16	19
Ratio 40 : 1						
8840-FD-.17-6CZ1	1-1/2	0.17	12-9/16	3-7/16	2-13/16	5
8840-FD-.17-8CZ1	2	0.17	13-1/16	3-7/16	3-5/16	6
8840-FD-.17-12CZ1	3	0.17	14-1/16	3-7/16	4-5/16	9
8840-FD-.17-16CZ1	4	0.17	16-1/16	4-7/16	5-5/16	13
8840-FD-.17-20CZ1	5	0.17	18-1/16	5-7/16	6-5/16	16
8840-FD-.17-24CZ1	6	0.17	20-1/16	6-7/16	7-5/16	19

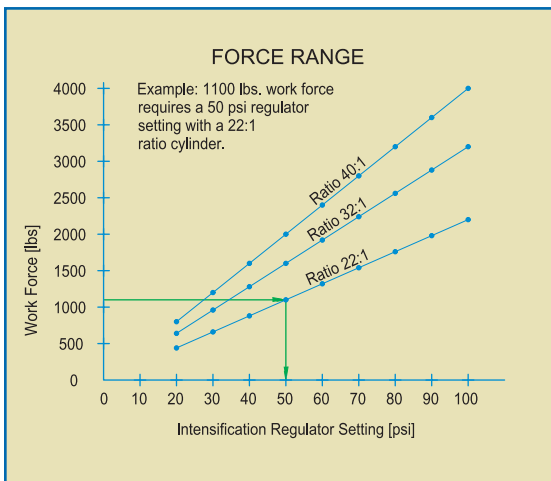

OHMA® Weld Cylinder
 Bore: 2"
 Ratio: 22:1
 Mounting Style: Front Dovetail
 Power Stroke: 0.26"
 Total Stroke: 4"
 Front Block: Multi Position
 Seal Revision: Z1

8 8 22 -FD- .26- 16 C Z1

CODING EXAMPLE

Rod end style, port location, total stroke, ratio and power stroke modifications are available upon request. For details, consult with CenterLine.

Cylinder Hook-up & Operating Instructions

To ensure proper cylinder performance, the following instructions must be observed:

For straight acting cylinder applications:

1. Position the work so the cylinder does not bottom out during the advance or the power stroke. The cylinder's rated total stroke is the sum of the advance stroke and the power stroke, i.e. a 3" stroke, 0.20" power stroke OHMA® cylinder has a maximum advance stroke of 2.80 inches before intensification. This applies to all cylinder model types. NOTE: Be sure to compensate for tooling deflection and tip wear.
2. Tooling should be mounted so that work is performed at the center of the rod. Offset loads may result in premature wear to the seals or nose bushing.
3. Tooling weight and break-away force must be within the allowable return force range for the cylinder.

Return Force Chart (at 100 PSI)		
Bore Size (in.)	Mounting Style	Return Force (lbs)
1-1/2	FNP	125
1-3/4	RH, STUD, FBL, FF, FNP, PIN, FD	140
2	RH, STUD, FBL, FF, FNP, PIN, FD	210
2-5/8	RH, STUD, FBL, FF, FNP	390

4. Never strike the barrel or rod to align the cylinder.
5. Unauthorized modifications will void CenterLine's warranty.

For all applications:

6. The cylinder may be mounted in any orientation, but the fluid line leaving the cylinder should travel upward toward the fluid reservoir. **Cylinders operating in the inverted position require an optional bleeder port in the rod end.**
7. For all ports use either brass or plated steel fittings that are free of rust and dirt. At no time should hydraulic fittings be used with an OHMA® cylinder as they restrict the flow of fluid resulting in slower cylinder operation.
8. For all lines use fluid compatible air hose or low pressure hydraulic steel tubing with a suitable ID that will not restrict flow. Consult the following table for sizing the hose or tubing used to install the reservoir.

Hose Sizing and Length Data			
Function	Cylinder Bore (in.)	Min. Size (in.)	Max. Length (ft.)
Air	1-1/2 to 2	3/8	20
Air	2-5/8	3/8	20
Fluid	1-1/2 to 2	1/2	10
Fluid	2-5/8	3/4	10

9. The OHMA® cylinder should be cycled several times after installation to remove any air trapped in the cylinder from the installation process. If air remains trapped in the lines the cylinder may be bled using the bleeder port on the cylinder.

NOTE: Not all OHMA® cylinders have bleeder ports.

To use this bleeder port, remove pressurized air from the system. Slowly loosen off the bleeder screw and wait until the fluid flowing from the bleeder port contains no additional air. Tighten the bleeder screw and then cycle the cylinder and confirm proper force is being generated. Generally, use of the bleeder port will not be required if the cylinder rod end is pointing downward or if it is mounted in a horizontal position with the fluid port pointing upward.

10. The cylinder should be operated in a clean environment. If the cylinder is removed from operation, seal all ports immediately upon removal.

Reservoir Hook-up & Operating Instructions

To ensure proper cylinder performance, the following instructions must be observed:

1. Choose a reservoir which has been properly sized for the selected cylinder or group of simultaneously operating cylinders.
2. Mount the fluid reservoir as close to the cylinder as possible and above the cylinder's "ADVANCE" port (Port EE2). If a manifold is being used with the system, to distribute fluid to more than one OHMA® cylinder, it must be the same size as the fluid port on the reservoir. This manifold should also be mounted above the cylinder's advance port. The distance from the reservoir to manifold must not exceed 20 feet. Consult with CenterLine if there are any questions about length of line.

To permit natural bleeding of the system, the fluid lines should be routed in a continuously upward direction from the OHMA® cylinder to the fluid reservoir. Failure to comply with this condition may result in loss of output force as a result of air being trapped in the lines feeding the OHMA® cylinder. By following this simple rule any air introduced to the system will naturally vent through to the reservoir.
3. For all ports use either brass or plated steel fittings which are free of rust and dirt. At no time should hydraulic fittings be used with an OHMA® cylinder as they restrict the flow of fluid resulting in slower cylinder operation.
4. For all lines use oil compatible air hose or low pressure hydraulic tubing. For sizing the hose or tubing used for the reservoir installation consult the table on page 27.
5. Connect the fluid reservoir to a filtered air supply. The smaller bore size weld cylinders (1-3/4" to 2-5/8" bore) are self-lubricating, a lubricator is not required. As a minimum condition, one air line regulator is required for proper fluid reservoir installation. This regulator, the intensification regulator, is connected to the INT AIR IN port on the reservoir & will be used to adjust the output of the OHMA® cylinder. Applications where a cylinder is required to operate at two or more intensification pressures (i.e. robot application welding two and three metal thicknesses) must incorporate a "quick dump" style regulator. This will ensure the various weld force requirements are reliably produced. As an option, a second regulator may be installed in the system to control the advance speed of the OHMA® cylinder. Refer to STANDARD CONFIGURATION and DELICATE TOUCH options (pages 33-35) for proper positioning within the system.
6. OHMA® cylinders utilize a combination of BUNA N (Nitrile) and polyurethane seals. Lightweight fluids that are compatible with these materials are recommended.

Typical fluid characteristics include:

- low viscosity to maximize speed (not more than ISO 22 @ 40° C)
- normal (10-50° C) operating temperature
- no phosphate ester components

Note: maximum pressure developed by cylinder in reference to fluid at 100 PSI:

1-1/2" Bore: 905 psi 2" Bore: 1592 psi
 1-3/4" Bore: 957 psi 2-5/8" Bore: 1756 psi

These standards must be followed to optimize cylinder operation.

Synthetic Fluids

Quaker Quintolubric 220
 Houghton Cosmolubric 130 HF

Manufacturer	Fluid
Exxon	Spinesstic 22
Eppert	EPPCO SPINDLE OIL 100 (ISO 22)
Imperial	NUTO A22
Mobil	VELOCITE #10, DTE 22
Petro Canada	HARMONY AW22
Shell	TELLUS 22
Sunoco	SUNVIS 922
Texaco	SPINDURA 22

Valve Selection

For ISO style reservoirs, a 5 port, 4 way externally air piloted valve body conforming to ISO standard 5599-1 is required. This standard essentially defines the valve's body interface geometry (port size and location, mounting hole size and location), which mates with the machined manifold provided on the top of the reservoir. For the 4 inch bore reservoir only, an ISO size 2 valve construction is required. For all other reservoirs, an ISO size 4 valve construction is required. Note that pilot air only supplied to Port 14 on ISO style reservoirs. ISO size 2 valves should have a minimum Cv rating of 2.0. ISO size 4 valves should have a minimum Cv rating of 6.0. Consult with CenterLine for applications requiring double solenoid valves with independent air pilots.

For ASB style reservoirs, a 5 port, 4 way externally air piloted valve body conforming to SAE standard J2051 is required. The requirements for valve function are as described for the ISO counterpart. The ASB (Automotive Sub Base) standard calls out a different port and mounting hole size and location than the ISO standard, so these two standards are not interchangeable. For the 4 inch bore reservoir only, an ASB size 250 valve construction is required. For all other reservoirs, an ASB size 500 valve construction is required. Minimum Cv rating for ASB size 250 is 2.0 and for ASB size 500 is 6.0.

Fluid Reservoirs Standard

CLR-400 Series

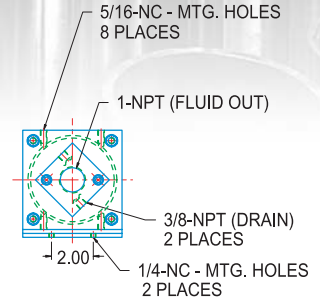
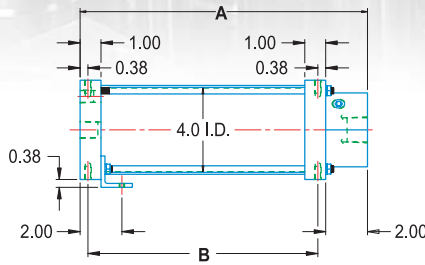
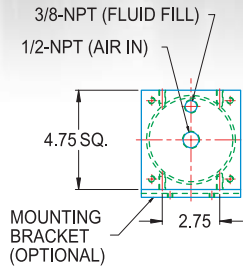

CLR-600 Series

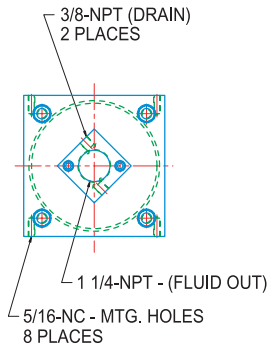
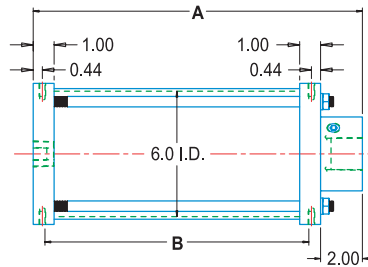
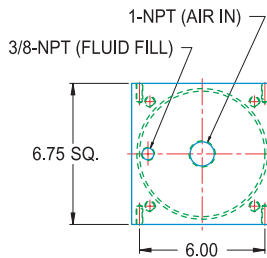

CLR-800 Series

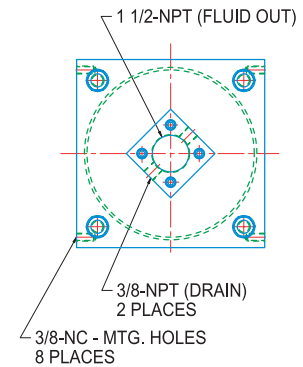
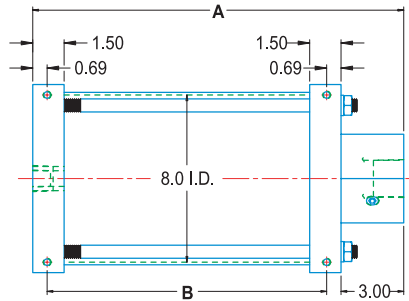
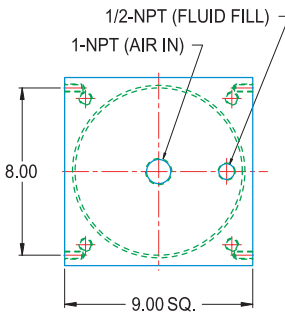

Model No.	A (in.)	B (in.)	Reservoir Capacity (in.)	*Usable Fluid Capacity (cu. in.)
4" Bore				
CLR-400-7	10-3/4	8	55	25
CLR-400-10	13-3/4	11	95	60
CLR-400-12	15-3/4	13	120	85
6" Bore				
CLR-600-8	11-3/4	8-7/8	155	60
CLR-600-10	13-3/4	10-7/8	210	115
CLR-600-12	13-3/4	12-7/8	270	170
8" Bore				
CLR-800-8	13-3/4	9-3/8	275	100
CLR-800-10	15-3/4	11-3/8	375	200
CLR-800-12	17-3/4	13-3/8	475	300

*NOTE: Usable Fluid Capacity represents the maximum volume of fluid that can be used to operate an OHMA® cylinder without risk of aeration. For greater "Usable Fluid Capacity" needs, larger fluid reservoirs are available.

Fluid Reservoirs

ISO & ASB Style

GENERAL GUIDELINES

Always use a fluid reservoir having an equal or larger bore size than the cylinder bore. This will safeguard against agitating the fluid and ensure it will not become contaminated with air bubbles. The presence of air in the fluid results in reducing the cylinder's force output. The fitting and hose (tubing) size is dependent upon the reservoir port sizes.

- Step 1** Once a suitable OHMA® cylinder is selected, determine its fluid requirement needs. The cylinder charts for each standard OHMA® cylinder list this information.
- Step 2** Compare the cylinder's fluid requirement with the Usable Capacity ratings of the available reservoirs. When operating more than one cylinder from one fluid reservoir, the sum of each cylinder's fluid requirement must be used in choosing a suitable fluid reservoir, other restrictions may apply. Contact CenterLine for information concerning the operation of multiple cylinders from one fluid reservoir.
- Step 3** For all reservoir styles, 2 valves are required. The ADVANCE valve extends the OHMA® cylinder working piston rod and also switches the air to return both the advance piston rod and the intensifier piston rod. The INTENSIFIER valve extends the intensifier piston rod, which allows the OHMA® cylinder to develop the high tip force required for proper welding. The ADVANCE valve must be designed as a "pressure select" type, as shop air is fed into the exhaust ports of the ADVANCE valve and flows "backwards" through the valve. In addition, when utilizing the delicate touch feature option, port EB (ASB style valve) or Port 5 (ISO style valve) will see a higher air pressure than Port EA (ASB style valve) or Port 3 (ISO style valve). This is due to the unique design of the delicate touch pneumatic circuit, which provides a regulated low air pressure to extend the OHMA® cylinder working piston rod when dealing with light gauge or lightly clamped work pieces, but allows full shop air pressure to be used for the return stroke, minimizing cycle time and thus maximizing production rate. Do not use flow control valves on an OHMA® cylinder as erratic cylinder operation will occur.

The INTENSIFIER valve is plumbed in standard fashion, and normally functions as a 3 way valve. In rare circumstances, this valve may be used for its 4 way function, but usually not in resistance welding applications.

ISO Model No.	ASB Model No.	A (in.)	B (in.)		C (in.)		D (in.)		E (in.)	F (in.)	Fluid Capacity (cu. in.)	Usable Capacity (cu. in.)
			ISO	ASB	ISO	ASB	ISO	ASB				
4" Bore												
CLR-ISO-4A4-7	CLR-ASB-4A250-7	11	7-3/4	8-7/8	4-3/4	5-1/4	7-15/16	7-3/4	2-3/4	4-5/8	55	25
CLR-ISO-4A4-10	CLR-ASB-4A250-10	14	7-3/4	8-7/8	4-3/4	5-1/4	10-15/16	10-3/4	2-3/4	4-5/8	95	60
CLR-ISO-4A4-12	CLR-ASB-4A250-12	16	7-3/4	8-7/8	4-3/4	5-1/4	12-15/16	12-3/4	2-3/4	4-5/8	120	85
6" Bore												
CLR-ISO-6A4-8	CLR-ASB-6A500-8	12-1/4	10-1/16		7		8-7/8		6	6	155	60
CLR-ISO-6A4-10	CLR-ASB-6A500-10	14-1/4	10-1/16		7		10-7/8		6	6	210	115
CLR-ISO-6A4-12	CLR-ASB-6A500-12	16-1/4	10-1/16		7		12-7/8		6	6	270	170
8" Bore												
CLR-ISO-8A4-8	CLR-ASB-8A500-8	13-3/4	11-9/16		9		9-1/8		8	8	275	100
CLR-ISO-8A4-10	CLR-ASB-8A500-10	15-3/4	11-9/16		9		11-1/8		8	8	375	200
CLR-ISO-8A4-12	CLR-ASB-8A500-12	17-3/4	11-9/16		9		13-1/8		8	8	475	300
*NOTE: Usable Capacity represents the maximum volume of fluid that can be used to operate an OHMA® cylinder without risk of aeration. For greater "Usable Capacity" needs, larger fluid reservoirs are available.												

Reservoir Port Sizing Chart (in.)

Bore	Side Ports	Exhaust Ports	Fluid Port	Mtg. Hole Size
4	3/8	3/8	1	5/16-18
6	1/2	3/4	1-1/4	5/16-18
8	1/2	3/4	1-1/2	3/8-16

For instructions on valve selection for ISO & ASB reservoirs, refer to page 28.

Pneumatic Schematic Standard Hook-up

The standard hook-up schematic shown below outlines the basic system requirements needed to operate the OHMA[®] weld cylinder. In this configuration, one regulator is used to control air pressure that is fed to the **INTENSIFICATION VALVE** (cylinder intensify) and full line air pressure is supplied to the **ADVANCE VALVE** to advance and retract the cylinder. Regulating the intensification pressure allows the user to adjust the force output of the cylinder without compromising low pressure advance and return speeds. An optional pressure switch is used to verify that intensification air pressure is present. An optional pressure transducer port may be added to the cylinder where hydraulic pressure monitoring is required. Hydraulic pressure monitoring may be used to verify correct cylinder force output. The schematic assumes the use of the OHMA[®] ISO or ASB style fluid reservoir package, however, this approach may also be used with a fluid reservoir and remote valve package.

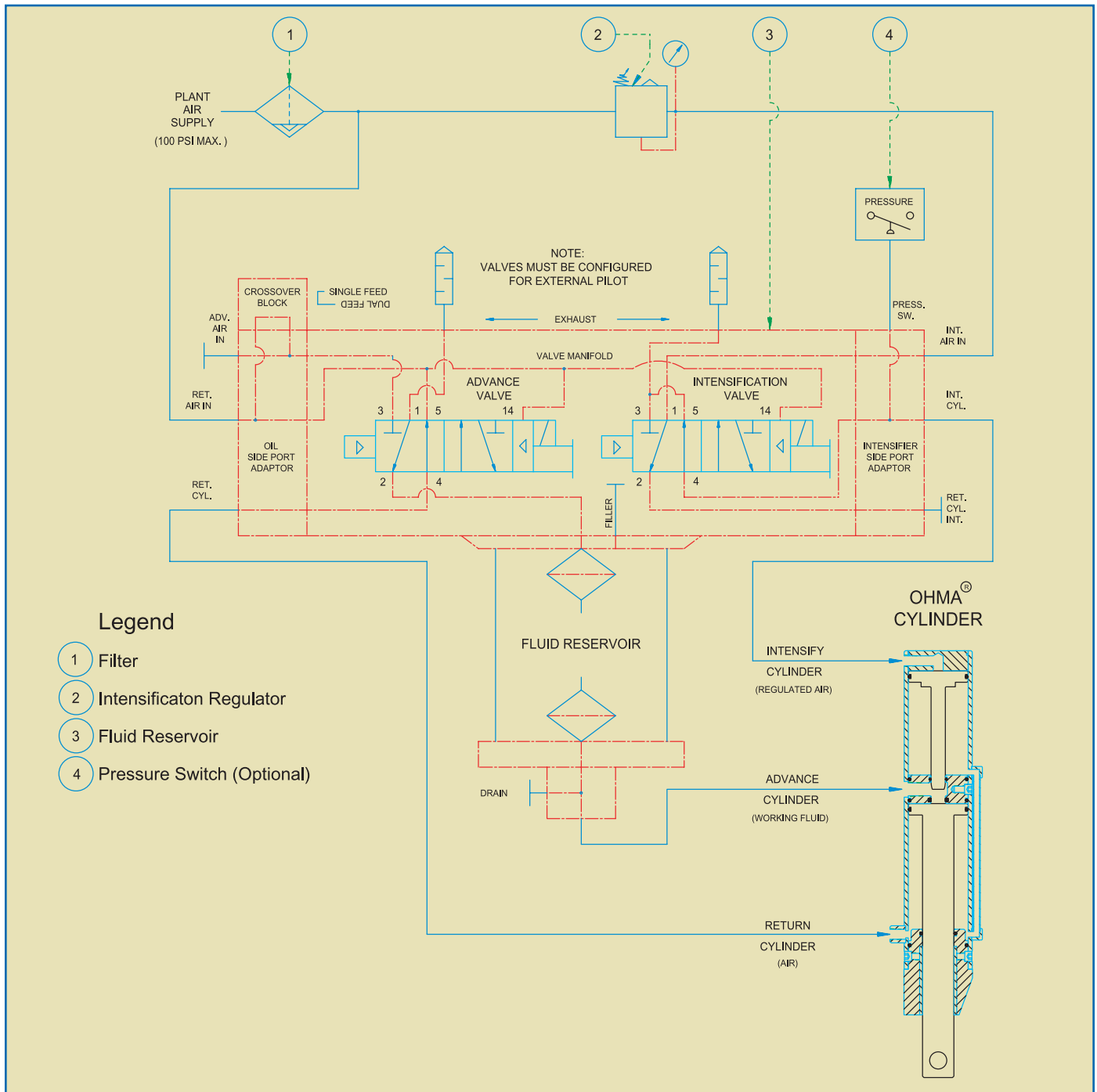

The simplicity of the OHMA[®] cylinder's method of operation also allows for many unique hook-up configurations. Several of these configurations are: multiple intensification strokes, programmable air pressure settings and programmable advance strokes. Contact CenterLine to obtain information on how to maximize cylinder performance through alternate hook-up configurations.

Pneumatic Schematic "Delicate Touch" Hook-up

The schematic below shows two hook-up options for the OHMA[®] cylinder. To provide full control of the cylinder's initial advance stroke impact, the delicate touch hook-up option includes a regulator (regulator 2) at the position shown. Full line pressure is used to retract the cylinder.

Applications requiring programmable retract strokes can be achieved by adding a blocking valve between the reservoir and cylinder. Energizing the blocking valve prior to the completion of the return stroke interrupts the flow of fluid back to the reservoir thus maintaining the working piston in a partially extended position. An optional pressure switch is used to verify that intensification air pressure is present. An optional pressure transducer port may be added to the cylinder where hydraulic pressure monitoring is required. Hydraulic pressure monitoring may be used to verify correct cylinder force output.

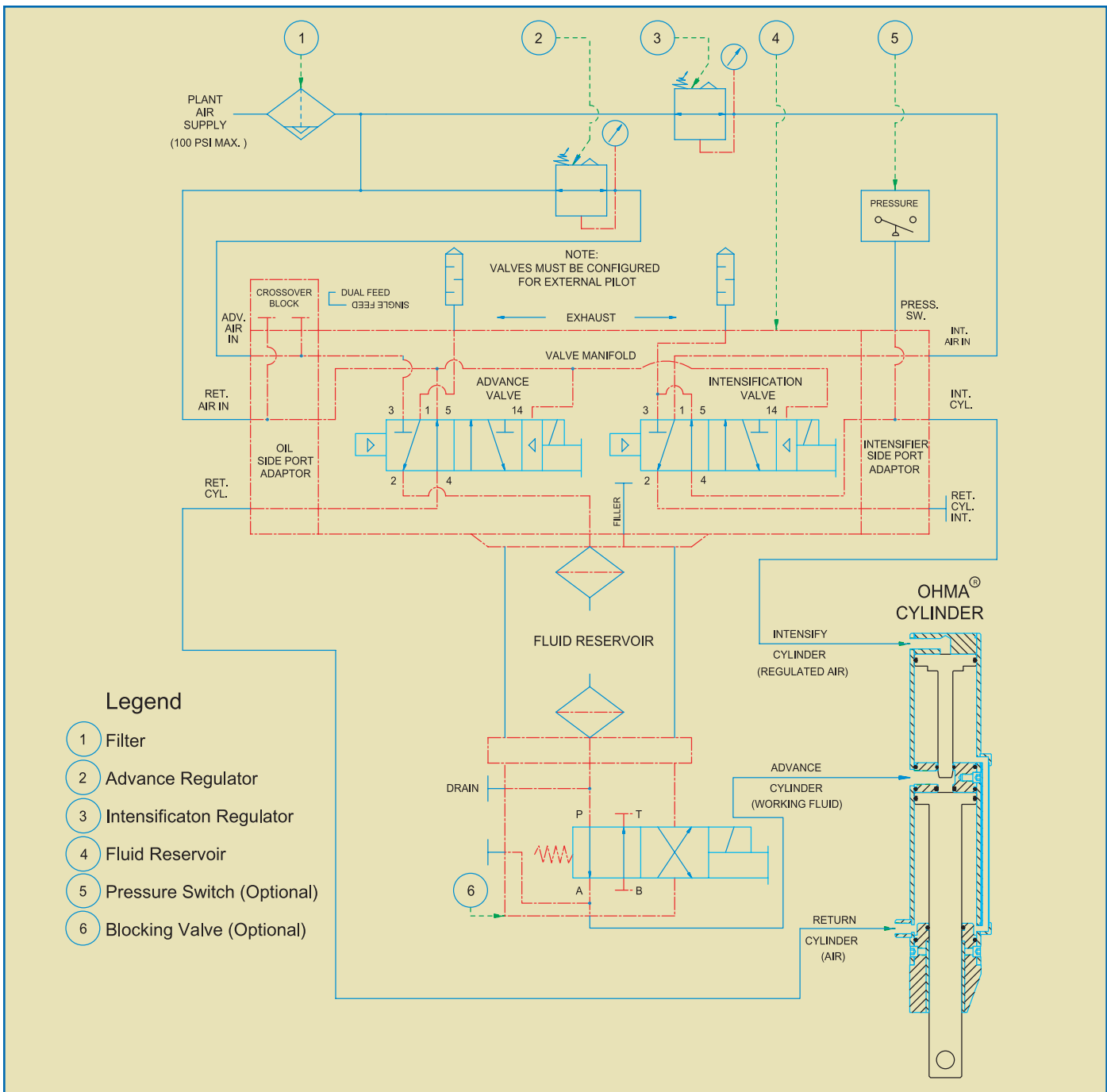

The simplicity of the OHMA[®] cylinder's method of operation also allows for many unique hook-up configurations. Several of these configurations are: multiple intensification strokes, programmable air pressure settings and programmable advance strokes. Contact CenterLine to obtain information on how to maximize cylinder performance through alternate hook-up configurations.

Pneumatic Schematic

Standard Configuration

The basic OHMA® cylinder hook-up is the "Standard Configuration". This hook-up allows for specific control of the intensification air pressure.

"Delicate Touch"/Blocking Valve

The "Delicate Touch"/Blocking Valve option allows the OHMA® cylinder to be operated with separate air pressure settings. This hook-up configuration is desirable for situations requiring precise control over initial advance stroke impact force.

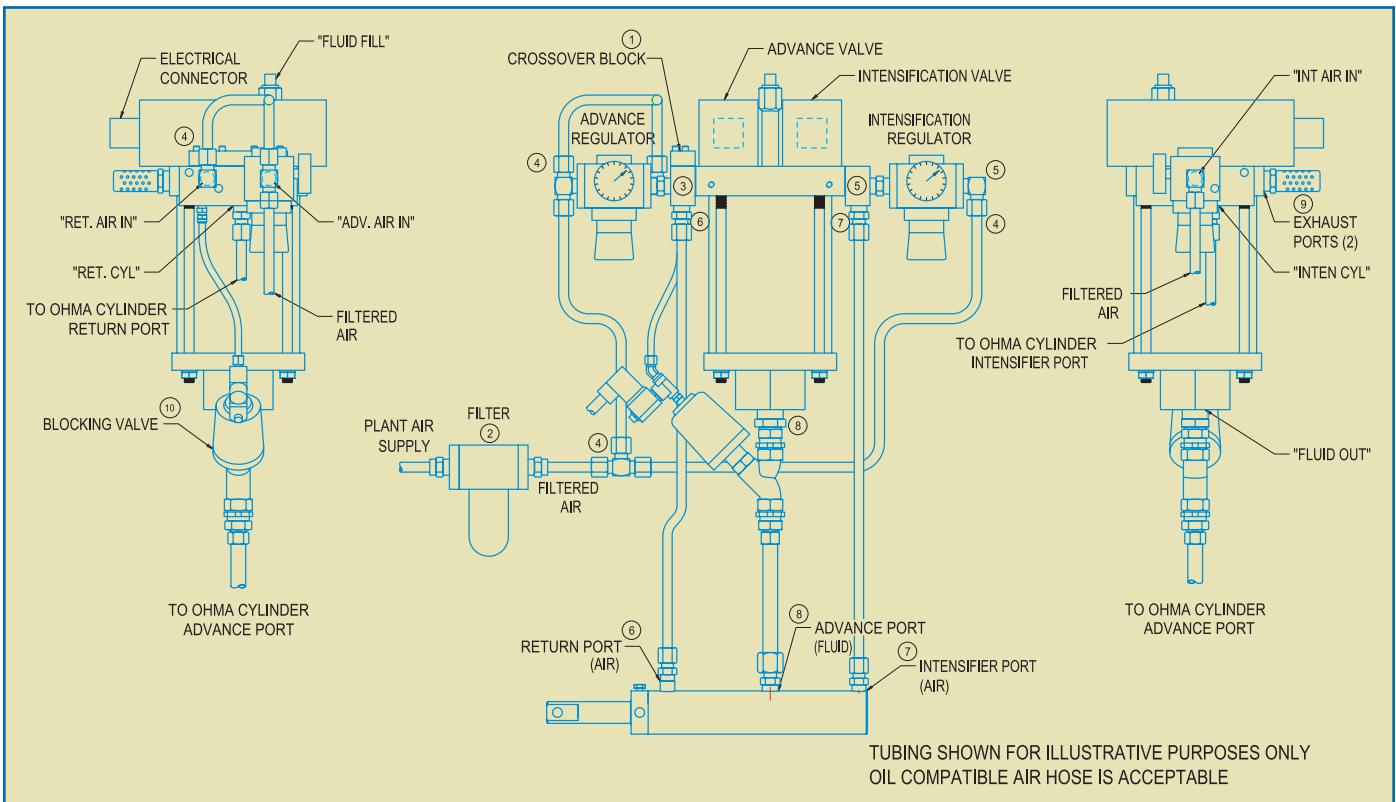

Note: 1, 3 and 10 apply only to the "Delicate Touch"/Blocking Valve option reservoir hook-up.

Installation Instructions

- 1 Remove the CROSSOVER BLOCK, invert it and re-install.
- 2 Connect the PLANT AIR SUPPLY to the inlet port of a FILTER which is sized for the system.
- 3 Connect the ADVANCE REGULATOR to the "ADV. AIR IN" port on the fluid reservoir.
- 4 Tee the outlet port from the FILTER to the "RET. AIR IN" port and the ADVANCE REGULATOR (for Delicate Touch option if applicable) on the fluid reservoir. Also, tee the outlet port from the FILTER to the INTENSIFICATION REGULATOR.
- 5 Connect the INTENSIFICATION REGULATOR to the "INT AIR IN" port on the fluid reservoir.
- 6 Connect the "RET. CYL" port on the fluid reservoir to the cylinder RETURN PORT (AIR).
- 7 Connect the "INTEN CYL" on the fluid reservoir to the cylinder INTENSIFIER PORT (AIR).
- 8 Connect the "FLUID OUT" port on the fluid reservoir to the BLOCKING VALVE which is then connected to the cylinder ADVANCE PORT (FLUID).
- 9 Put mufflers on the EXHAUST PORTS (2) of the fluid reservoir.
- 10 Applications requiring programmable retract strokes can be achieved by adding a blocking valve between the reservoir and cylinder. The blocking valve is an optional component.

NOTE: Use of hydraulic fittings will restrict the flow of fluid to the cylinder. Since the fluid pressure in the hose/tubing is not above the system air pressure supplied by the user, standard air fittings should be used.

Other Products

CenterLine manufactures a variety of products to satisfy resistance welding and metalworking needs. Contact CenterLine for additional information on other products.

RESISTANCE WELDING EXPERTISE

CenterLine has a broad range of proven resistance welding gun solutions.

The CenterLine product range includes:

- basic solutions to satisfy your general needs
- custom solutions to address your unique requirements
- innovative solutions to meet your future needs.

Our knowledge and experience are reflected in a family of resistance welding gun solutions that are well suited for tough industrial environments. A culture of continuous improvement has helped us improve our product line by simplifying installation, improving durability, and requiring minimal maintenance.

We have diverse engineering and manufacturing capabilities to turn your unique requirements or ideas into a solution that will give you a competitive advantage.

Standard CenterLine solutions all offer low-impact operation. Our STAAC® air cylinder, OHMA® air/oil cylinder, or servo-electric actuator, will help ensure you can:

- maximize up-time by decreasing wear
- reduce operating cost by maximizing consumable life
- minimize noise
- decrease shock and vibration
- minimize electrode skidding
- control dimensional variation
- improve weld appearance

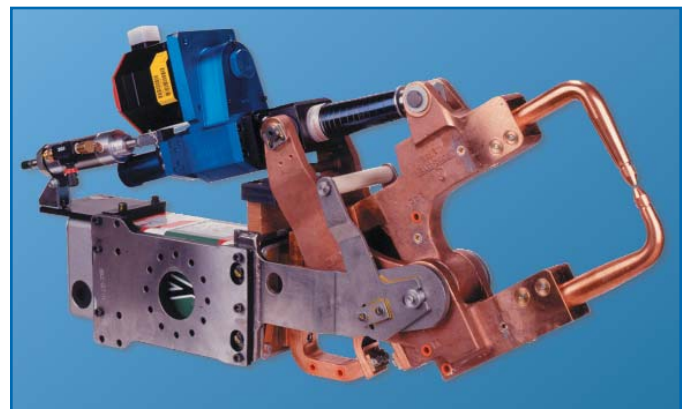
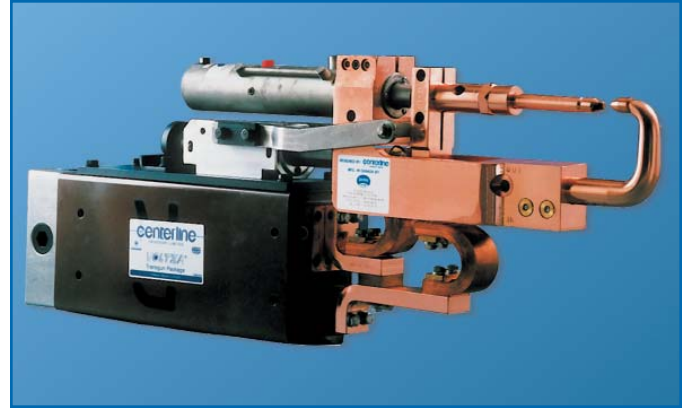

Other Products

Resistance Welding Products

The CenterLine Electrodes and Allied Products Division is dedicated to the manufacture and supply of cold-formed electrodes, welding tips and fixtures, adapters, holders, seam welding wheels, patented weld nut electrodes, special welding dies, shunts and cables, and a host of other consumable products.



AMSI Welding Cylinders

CenterLine offers a comprehensive line of conventional pneumatic weld cylinders in collaboration with American Machining Specialties Incorporated (AMSI):

- Dual Piston Cylinders
- Triple Piston Cylinders
- Pre-Lube Cylinders
- Retract Cylinders
- Proximity Switch Cylinders
- Hydraulic Cylinders

The line of standard cylinders provide direct replacements for a large variety of weld cylinder applications. In addition to the standard line we also offer in-house design to fit our customer's specific requirements as well as replacement seal kits and parts for competitive brands.



OHMA® Piercing Cylinders

The OHMA® piercing cylinder offers a robust design and remains one of the most practical and trouble-free systems available today. By using shop air pressure and hydraulic fluid, the OHMA® cylinder produces work forces ranging from one ton to hundreds of tons. Rod, stroke and mounting style options make the OHMA® cylinder suitable for virtually all metalworking applications.



OHMA® Press Packages

The OHMA® press family is a collection of presses ranging from 4 to 70 tons. The presses are designed to satisfy production needs, prototype work or serve as an all purpose press. The design offers total flexibility with a soft touch, non-shock approach to the part and a 1/2" high force work stroke. These presses are ideal for piercing, pierce nut installation, crimping, coining, marking, forming, stamping, etc.



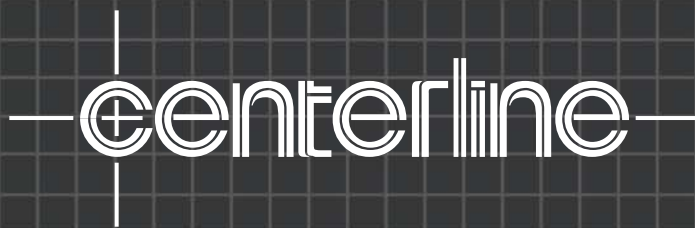

CenterLine (Windsor) Limited

Automation Components Division
655 Morton Drive
Windsor, ON N9J 3T9
Canada

U.S.A.:
P.O. Box 321187, Detroit, MI 48232-1187

Tel: 519-734-8330
Toll Free: 800-268-8330
email: info@cntrline.com

www.cntrline.com