

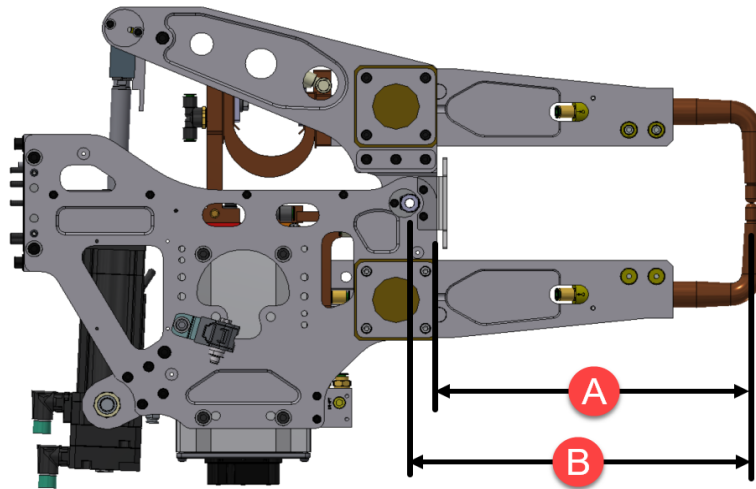

FlexGun™ Ultra/Ultra HC



Max. Angle of Opening [deg]	Actuator Plane to Pivot Axis [mm]
18.5	373

Ultra X and Ultra X HC Maximum Tip Force Rating Vs. Throat

Useable Throat Depth "A" [mm]	Pivot to Weld Point "B" [mm]	Gun Ratio	Approx. Tip Opening [mm]	10 mm Pitch Servo Actuator ¹		5 mm Pitch Servo Actuator ¹	
				Max. Weld Force [kN]	Max. Weld Force [lbf]	Max. Weld Force [kN]	Max. Weld Force [lbf]
250	285	1.31	95	8.1	1817	8.9	2000
275	310	1.20	98	7.4	1670	8.9	2000
300	335	1.11	106	6.9	1546	8.9	2000
325	360	1.04	114	6.4	1438	8.9	2000
375	410	0.91	130	5.6	1263	8.9	2000
400	435	0.86	138	5.3	1190	8.9	2000
425	460	0.81	146	5.0	1126	8.9	2000
475	510	0.73	162	4.5	1015	9.0	2000
525	560	0.67	178	4.1	925	8.2	1849
575	610	0.61	194	3.8	849	7.6	1698
600	635	0.59	201	3.6	815	7.3	1631

¹Weld actuator has built in water cooling.

All weld force ratings are subject to change depending on arm, electrode and cap requirements for specific applications.

8.9 kN [2000 lbf] limit is based on typical standard cap geometries, electrode lengths and library arm designs. Higher forces may be possible with special engineering considerations.

The Ultra X gun style is optimized for a 10 mm pitch actuator.